

NOTES:

1. REFER TO B/CS UNIFIED DESIGN GUIDELINE MANUAL FOR ACCEPTED RIGHT OF WAY AND PAVEMENT WIDTH.
2. COLLECTOR STREETS WILL BE REQUIRED TO USE 8" REINFORCED CONCRETE (28 DAY STRENGTH = 3500 PSI)

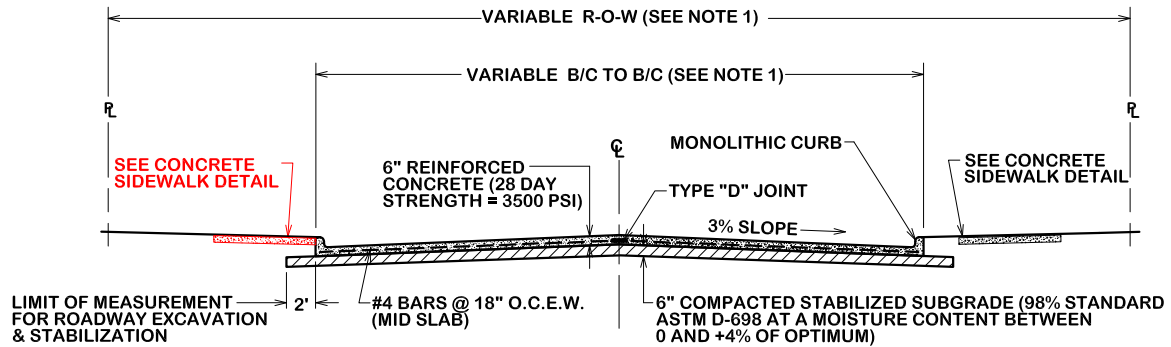

REINFORCED CONCRETE PAVEMENT



CITY OF BRYAN
The Good Life, Texas Style.

TYPICAL STREET SECTION

DATE

FEB. 2021

**B/CS UNIFIED
STANDARD DETAIL**

DETAIL NO.

ST4-05



CITY OF COLLEGE STATION