

# **Unified Stormwater Design Guidelines**

**City of Bryan  
City of College Station**

**AUGUST, 2012**

# **Unified Stormwater Design Guidelines**

**City of Bryan**

**City of College Station**

**AUGUST 2012**

***Sentences and/or paragraphs that are double underlined indicate revisions that were made from the 2009 manual.***

## **Acknowledgements**

Appreciation is expressed to participants in the Bryan / College Station Drainage Design Guidelines Form for their assistance during numerous work meetings and discussions, and to a working committee including engineering staff of both Cities. In addition, appreciation is extended to William Lowery, P.E. of the Texas Engineering Extension Service, Texas A&M University System, for his work in facilitating meetings and discussions and in preparation of the final document.

# Unified Stormwater Design Guidelines

## TABLE OF CONTENTS

	<u>Page</u>
<b><u>Section I - Introduction</u></b>	
A. Purpose .....	1
B. Source of Authority .....	1
C. Definitions .....	1
D. Considerations .....	1
<b><u>Section II - Policies</u></b>	
A. Stormwater Principles .....	1
B. Framework for Stormwater Management Terms .....	1
1. Watersheds .....	2
2. Basins .....	2
3. Land Development Projects .....	3
C. Watershed Management .....	7
1. Primary Drainage System .....	7
2. Secondary Drainage System .....	9
3. Detention/Mitigation .....	10
4. Water Quality .....	11
5. Master Drainage Plan .....	12
D. Extent of Design .....	12
1. Threshold for Engineered Design .....	12
2. Study Limits .....	13
3. Special / Alternate Designs .....	13
4. Applicable Ordinance Requirements .....	13
E. Public Facilities .....	14
1. Principles for Public / Private Facilities .....	14
2. Maintenance Considerations .....	15
3. Easements and Right of Way .....	15
F. Private Facilities .....	17
1. Detention Systems .....	17
2. Conveyance Systems .....	17
<b><u>Section III - Stormwater Administration</u></b>	
A. Permitting Process .....	1
1. Step One .....	1
2. Step Two .....	1
3. Step Three .....	1
4. Step Four .....	1

# Unified Stormwater Design Guidelines

## TABLE OF CONTENTS

<b>B.</b>	Stormwater Planning Conference (Step 1) .....	2
1.	Stormwater Management Concept .....	2
2.	Preliminary Drainage Report (Step 2) .....	4
<b>C.</b>	Drainage Report Requirements (Step 3) .....	4
1.	Purpose of Report .....	4
2.	Abbreviated Drainage Plan .....	5
3.	Drainage Report Contents .....	6
4.	Drainage Report Drawings .....	10
<b>D.</b>	Construction Drawings and Specifications .....	12
1.	Compliance with Drainage Report .....	12
2.	Compliance with Design Guidelines .....	13
<b>E.</b>	Record Drawings .....	13
1.	Required Plans .....	13
2.	Engineering Attestation .....	13
3.	Construction Attestation .....	14

### **Section IV - Related Permitting**

<b>A.</b>	FEMA-Designated Floodplains .....	1
1.	Regulatory Floodplains .....	1
2.	Regulations .....	1
3.	Managing Encroachment .....	1
4.	Procedures .....	2
<b>B.</b>	Stormwater Quality .....	2
<b>C.</b>	Governmental Entities in Bryan-College Station Region .....	3
1.	Brazos County .....	3
2.	TxDOT .....	4
3.	Brazos River Authority .....	4
4.	Texas A&M University System .....	5

### **Section V - Hydrology**

<b>A.</b>	Introduction .....	1
<b>B.</b>	Stormwater Runoff Calculation Methods .....	1
1.	The Rational Formula .....	1
2.	Natural Resource Conservation Service Methods .....	5
3.	Hydrograph Methodology .....	6

# Unified Stormwater Design Guidelines

## TABLE OF CONTENTS

C.	Applications .....	8
1.	The Rational Method .....	8
2.	Natural Resource Conservation Service (NRCS) Methods .....	8
3.	Dimensionless Unit Hydrograph Method .....	8
4.	Detention Facilities .....	8

### **Section VI - Hydraulic Design**

A.	Street Drainage .....	1
1.	Design Principles .....	1
2.	Performance Standards and Limitations .....	1
3.	Design Procedure .....	3
B.	Storm Drain Inlets .....	3
1.	Principles .....	3
2.	Street Inlet Criteria .....	4
3.	Types of Inlets .....	4
4.	Inlet Location .....	4
5.	Inlet Sizing .....	5
C.	Storm Drainage Systems .....	6
1.	Principles .....	6
2.	Initial Design Considerations .....	7
3.	Hydraulic Design Requirements .....	8
4.	Use of WINSTORM Program .....	10
D.	Open Channels .....	10
1.	Principles .....	10
2.	Determination of Water Surface Profiles .....	11
3.	Design of Open Channels .....	13
4.	Roadside Ditches .....	16
5.	Modification of Natural Watercourses .....	16
E.	Detention Facilities .....	19
1.	Principles .....	19
2.	Design Parameters .....	20
3.	Physical Characteristics for Dry-Type Facilities .....	22
F.	Culverts & Bridges .....	23
1.	Principles .....	23
2.	General Parameters .....	24
3.	Design Limitations and Performance Criteria .....	24
4.	Physical Configuration .....	26
5.	Bridge and Culvert Hydraulic Design .....	27

G.	Flood Plains .....	29
1.	Principles .....	29
2.	Identification of Floodplains .....	30
3.	Regulations .....	30
4.	Procedures .....	31

### **Section VII - Erosion & Sedimentation**

A.	Principles .....	1
1.	Temporary and Lasting Measures .....	1
2.	Erosion Reference .....	1
3.	Scope of Actions .....	2
B.	Non-Permanent Erosion Control Measures .....	2
C.	Permanent Erosion Control Measures .....	2
1.	Land Grading .....	3
2.	Unpaved Areas and Swales .....	3
3.	Channels .....	4
4.	Energy Dissipation .....	4
5.	Best Practices .....	5

### **Section VIII - Water Quality**

A.	Principles .....	1
B.	Imbedded Objectives .....	1
C.	Regulatory Context .....	2
1.	National Regulations .....	2
2.	State of Texas Regulations .....	4

### **Section IX - Appendices**

A.	Authority
B.	Region's Watersheds
C.	Computational Information
D.	Technical Design Summary
E.	<u>Best Practices</u>
F.	<u>Quality Control</u>
G.	Glossary
H.	General References

**Section I**  
**Introduction**

**Unified  
Stormwater  
Design Guidelines**

**City of College Station  
City of Bryan**

**August 2012**



### A. Purpose

The standards and criteria in this document are promulgated to implement the intent of the stormwater management ordinances adopted respectively by the City of Bryan and the City of College Station for use in their respective jurisdictions. The term “**Guidelines**” is used throughout this document in reference to itself. The objective is to encourage uniformity of results through the use of unified criteria and sound practices in the planning, analysis, design, and construction of drainage facilities.

### B. Source of Authority

These Guidelines are regulatory in nature, deriving their authority from the stormwater management ordinances and floodplain management ordinances adopted from time to time by the City Council of each of the two cities.

### C. Definitions

Unless specifically defined in these Guidelines and/or in the Glossary, Appendix F, words or phrases used in these Guidelines shall be interpreted so as to give them the meaning they have in common usage and to give these Guidelines their most reasonable application. Responsibility for final interpretation of the meaning of language used herein rests with the City Engineer of each of the respective Cities.

### D. Considerations

#### *Managed Stormflow*

One of the basic purposes of these stormwater Guidelines is to assure that newly developing land areas are planned and designed in a manner that safeguards life, property, and public infrastructure from damage due to ill-managed storm flow.

#### *Guidelines Apply*

Inasmuch as platting must provide for right of way and easements that assure efficient conveyance of storm flow within streets, storm drains, and prepared swales or channels, these guidelines are applicable to all such platting proposals. Likewise platting must demonstrate suitable spatial relationships between proposed building sites and floodplain areas designated by the Federal Emergency Management Administration (FEMA). For these reasons, anyone interested in building real property or public or service infrastructure of any kind in either Bryan or College Station is obligated to demonstrate to the City that they are in substantial compliance with these Guidelines. Such compliance will be one of the measures by which the adequacy of any proposed land plan, preliminary plat, final plat, or site plan will be evaluated.

**Section II**  
**Policies**

**Unified  
Stormwater  
Design Guidelines**

**City of College Station  
City of Bryan**

**August 2012**

### **A. Stormwater Principles**

<i>Drainage System</i>	For purposes of regulation, the drainage system shall be divided into geographical and functional groupings. The drainage system consists of all natural and man-made features that collect or receive concentrated stormwater flow. Examples are swales or channels (natural or man-made), streets, storm sewers, minor streams and major streams.
<i>Primary and Secondary</i>	Functional division is separation of the drainage system into its primary and secondary components. The Primary System consists of major streams that convey collected stormwater through and out of the two cities, including primary tributaries thereof. The Primary System is made up of the watercourses that are part of the FEMA-designated floodplain management network, the geographic limits of which may be amended from time to time by the City. The Secondary System consists of all minor drainage ways, streets, storm sewers, and swales that collect stormwater and convey it to the Primary System.
<i>Storm Duration</i>	From a hydrologic standpoint, the Secondary System is sensitive to short duration, high intensity rainfall events. Flood effects occur suddenly and dissipate quickly, usually within a period of a few hours. By contrast the Primary System is sensitive to longer duration, moderate intensity rainfall events. Flood events occur over a longer period, with a slower rise to the fall from peak flows and flood elevations. This fundamental difference between the Primary and Secondary Systems forms the basis for strategies to manage stormwater and its effects within each.
<i>Unique Characteristics</i>	Geographical division involves separating the various streams and land areas into broad drainage areas having unique characteristics in terms of land cover, pattern of development, governmental jurisdiction, proposed land uses, and system interconnection. Recognition of these differences allows for logical formulation of policies and standards tailored to specifics rather than generalities.
<i>Known Problems</i>	Because the basic reason for regulating stormwater runoff and conveyance is to promote public safety, it must be emphasized that where persistent, known drainage problems exist, criteria more stringent than stated in these Guidelines may be necessary.

### **B. Framework of Stormwater Management Terms**

A great variety of terms are used in the science and administration of managing urban stormwater. To foster clarity and expediency in use of these Guidelines, a limited series of terms has been specially defined. The focus is on the definitions of drainage areas, land proposed for development, and the purposes of detention. The diagram in Figure II-1 offers a graphical representation supporting this

framework of terms. The principal terms coined below are in bold print in this Section and are capitalized throughout these Guidelines. The Glossary in Appendix F provides specific definitions of these and other key terms.

## 1. Watersheds

Every land area in the Bryan-College Station region is in a “**watershed**” of some description, each of which is associated with some kind of watercourse. For managing storm runoff in these areas it is useful to divide these areas according to the watercourses that drain them.

### *Named Streams*

For purposes of these Guidelines “**watersheds**” are all of the land areas contributing storm runoff to each of the principal watercourses making up the primary system. The primary system is divided into logical parts that are referred to as the “**Named Regulatory Watercourses**” listed in Table B-1, Appendix B. Reference maps of the principal watersheds are also included in Appendix B.

A hypothetical “Principal Named Watercourse” and the hypothetical watershed (“Watershed A”) it drains are sketched in Figure II-1.

## 2. Basins

### *Tributaries*

For purposes of these Guidelines a “**basin**” is defined as the land area drained by a tributary of a “Principal Named Watercourse”. Each “Principal Named Watercourse” has several tributaries (some possibly having localized names) that serve to help drain the **watershed**. Each **watershed** is made up of several **basins**, and all areas in a **watershed** are considered to be part of one of its **basins**.

### *Specific Limits*

The specific geographic limits of any **basin** are a function of topographic features that can only be determined through engineering study. Such limits must be determined when dictated by the characteristics of a proposed land development project as determined by the City Engineer or his/her designee during project review processes.

Figure II-1 illustrates the **basins** of a hypothetical **watershed**. In this sketch the “Principal Named Watercourse” has six tributaries, so the **watershed** is considered to have six **basins**. **Watershed “A”** has six identified **basins**, basins 1, 2, ... 6.

**3. Land Development Projects****a Land Areas**

- Enhanced Consistency* Land development projects occur in many shapes and sizes in a variety of locations. These Guidelines apply to all proposed projects but their application is a function of numerous variables. To enhance consistency in determining how these Guidelines apply to particular situations, the following land area terms will be used.
- Project Area* **Project Area**: The entire land holding associated with any proposed land development project will be considered the “**Project Area**”. This is to include the largest acreage of any combination of: the entire ownership, the entire parent tract, and/or the entire purchase option acreage, if any. This is true for all contiguously owned tract(s) or lots regardless of whether platted or not platted. It is also irrespective of whether construction (buildings or infrastructure) is planned on portions of the land near term and/or at some future time, however well or poorly defined.
- 2-Phase Project* In Figure II-1 hypothetical Project B is a two-phase project. Stormwater analysis and design for Phase 1 of Project B must consider Phase 2 to be part of the **project area**, even if Phase 2 facilities and/or buildings are planned for future construction. In addition, it must consider any “**Above-Project Area(s)**” and “**Pathway Area(s)**” as described below.
- Above-Project Areas* **Above-Project Areas**: These are any land areas that contribute storm runoff onto or through the **project area**. In Figure II-1 schematic projects A, C, and E all have “**above-project areas**” since upland areas contribute storm runoff to the **project areas**. Schematic projects “B” and “F” may or may not receive runoff from limited upland areas. Schematic Project “D”, in Basin 1, borders the **basin** divide and receives no runoff from upland areas, so it has no **above-project area**.
- Pathway Areas* **Pathway Areas**: As described in Paragraph C2 of this Section, “designated conveyance pathways”, however simple or complex, must be identified for every land development project. Conveyance pathways downstream of a **project area** may carry runoff from land that is not part of the **project area** or the **above-project area**. Areas discharging to a “conveyance pathway” downstream of the **project area** are considered “**Pathway Areas**”.
- Two Basins* In Figure II-1 Projects “A”, “B”, and “D” each include **pathway areas** along the “conveyance pathway” that would extend from the **project area** to the tributary, then to **Watercourse A**. Project “F” straddles the divide between basins, so it will have two “conveyance pathways” and two sets of **pathway areas**, one in each of the two **basins**. The extent of analysis, design, and improvement for the conveyance pathway and the land areas it drains varies as stipulated elsewhere in these Guidelines.

*Drainage Study Area*      **Drainage Study Area:** Every project will be considered as having a “**Drainage Study Area**” that is the **project area** at a minimum. As applicable, it may also include **above-project area(s)**, and/or **pathway area(s)**. To be considered complete, a “drainage study” must address all three components of a **drainage study area**, as well as the conveyance pathway itself to limits as determined under provisions of Paragraph D2 of this section. If such areas do not exist for a particular project, it shall be so stated in the drainage study report.

*Design Drainage Area*      **Design Drainage Area:** Every **drainage study area** will include any number of “**Design Drainage Areas**” that must be analyzed to determine the design storm flow for the purpose of sizing and placing stormwater management facilities of various types. This can vary widely, from a small area draining to a curb inlet, to many acres served by a channel and culvert.

### b. Purposes of Detention

*Two Purposes*      Detention is a useful stormwater management technique. As fully addressed in Paragraph C3 of this Section, it can be used for managing flood control over a broad area such as an entire **basin** or **watershed**. It can also be used to manage property-to-property conveyance of stormwater. Whether detention is required by these Guidelines is partially a function of how a **project area** is situated in a **watershed**. This gives rise to three types of detention as a function of the purpose.

*Not Design Type*      “Type” in this context does not relate to design characteristics of facilities used to accomplish detention objectives.

*Flood Control*      **Type 1 Detention (Flood Control):** The purpose of this type of detention is to manage runoff from a **watershed** or **basin**. A **project area** located near the bottom of a **watershed** will generally not require detention for this purpose. Schematic Project “E” in Figure II-1 illustrates this condition.

*Conveyance Mgmt.*      **Type 2 Detention (Conveyance Management):** The purpose of this type of detention is to manage the delivery of runoff from a property to neighboring (generally adjoining) properties. This may be necessary regardless of how a **project area** is situated along the length of a principal watercourse. In Figure II-1 schematic project “D” illustrates this condition because it may be low enough in the **watershed** not to warrant **Type 1 Detention**.

*Dual Purpose*      **Type 3 Detention (Dual Purpose):** Detention in this category is considered to have a dual purpose. It is important for both flood control and managing property-to-property conveyance. Schematic projects “A”, “B”, and “F” illustrate this condition. All three projects must drain to or through adjoining properties to reach a tributary, so detention may be required to satisfy conveyance criteria. In addition, because they are situated in the upper areas of a **watershed**, managing the peak discharge from them is likely to contribute to flood

control objectives for the **watershed** as a whole or for the **basin** in which each is located.

*No Detention*

In Figure II-1 schematic "Project C" illustrates a situation where detention may not be warranted. If low enough in the **watershed**, **Type 1 Detention** may be unnecessary, possibly even detrimental, to flood control objectives. Moreover, because it can drain directly into the principal watercourse, there may be no need for **Type 2 Detention**.

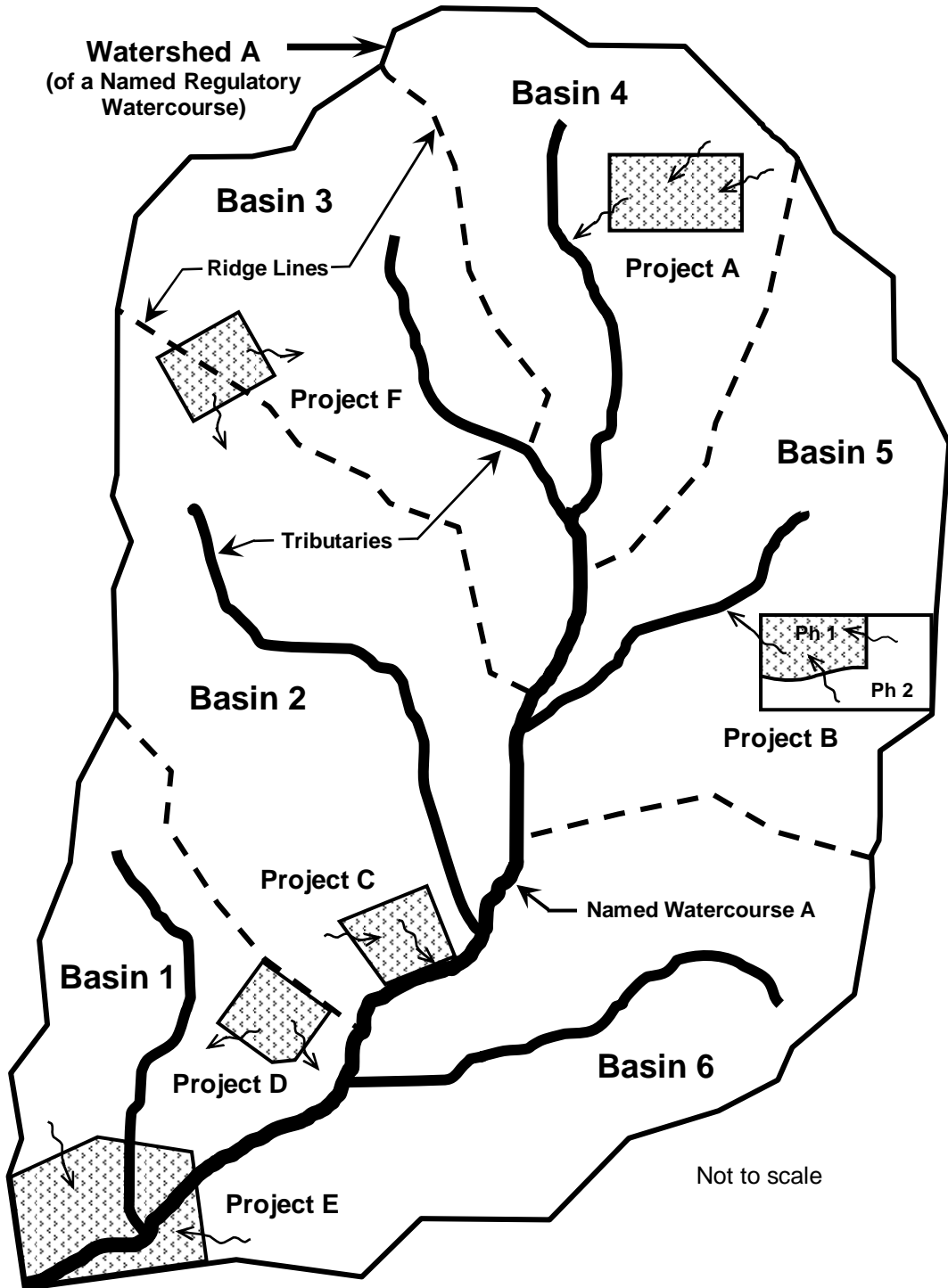

Figure II-1: Watershed – Basin – Projects Diagram



**C. Watershed Management****1. Primary Drainage System****a. Nature of Problems in Primary System**

<i>Floodplains</i>	Stormwater problems in the primary drainage system result from floodwaters rising out of the banks of natural streams and inundating adjacent natural floodplains. Symptomatic problems are flooding of building structures, overflow of bridges and culverts hampering traffic access, and damage to public and private infrastructure (utilities, roads, etc).
<i>Problem Causes</i>	<p>Problems in the primary system can be caused by the following:</p> <ul style="list-style-type: none"><li>• Inadequate capacity of crossing structures and failure to allow for overflow.</li><li>• Placing the finish elevation of the lowest floor of a structure situated adjacent to the Primary System below the existing or ultimate 100 year flood elevation.</li><li>• Inadequate or out-dated engineering studies that form the basis of the regulatory flood elevations.</li><li>• Failure to allow for increased discharge from, and resulting flood elevations in, upstream areas.</li><li>• Failure to control and limit increased stormwater discharge to downstream areas.</li><li>• Improper or ineffective alterations to natural channels that have the effect of “transferring” flood problems to upstream or downstream areas.</li></ul>
<i>Resulting Hazards</i>	The results are creation of hazards to life and damage to public and private properties. Remedial measures usually involve large capital improvements to channelize streams, create large detention facilities, or build larger crossing structures for roadways.
<i>Hydrologic Studies</i>	As a first step to dealing with these problems, the Cities adopted comprehensive hydrologic and hydraulic engineering studies for most of the primary system and tributaries thereof. These identify the flood discharge and flood elevations within the primary system, for existing and ultimate development conditions. Ultimate development conditions reflect the drainage situation as expected if the development within the City follows that projected in the City’s adopted comprehensive land use plan. In theory, the existing and ultimate flood conditions are known. Duly adopted flood studies will govern actions and treatments (whether public projects or associated with land development projects) that affect the primary system and its tributaries, consistent with state and federal regulatory requirements.

<i>Minimize Flooding</i>	The policies of the Cities are to encourage the efficient conveyance of stormwater through and out of the Cities within the primary system. The lowest floor of all structures adjacent to the primary system shall be kept at a level above the ultimate 100-year flood level, and no structure will be allowed within the existing 100-year flood path defined as the “floodway.” In order to eliminate sporadic and uncoordinated site improvements, modification of the floodway shall be restricted to projects engineered and treated in conformance with a comprehensive master plan established for regulatory channel reaches.
<i>Encroachments</i>	Unless stipulated otherwise in a City ordinance or other design guidelines, minor encroachments in the floodway fringe will be allowed for individual sites and developments, provided they are clearly part of a “Drainage Development Permit” approved by the City. Crossing roadway structures are allowable to include encroachments, provided they are designed to accommodate the range of ultimate design flows through them (or through and over them) to eliminate formation of hazards and damage to private property or public infrastructure.
<i>Regulations</i>	To implement this policy, stormwater management ordinances and design guidelines have been adopted by each City. Requirements vary along each channel reach to recognize the differences related to development conditions, expected increases in flood elevations, and the potential for damages.

### **b. Recognized Watersheds and Channel Reaches**

<i>Watershed Maps</i>	Figures B-1 through B-21 in Appendix B present maps of the drainage watersheds within and adjacent to the Cities. Watersheds are divided into “reaches” to recognize the relationships of geography, land uses, political jurisdiction, and proposed development relative to their effects on existing and ultimate storm flow and flood elevations. Within each watershed, the named regulatory streams are designated as part of the primary system, and individual reaches of each are, in some cases, identified for regulatory purposes.
<i>Watershed Landmarks</i>	Watershed identification is schematic in the figures. A land area is defined as being part of a given watershed if stormwater that falls upon it travels overland by natural or man-made pathways, and enters the main channel of the primary system of that watershed. The primary system and channel reaches are established by physical landmarks such as stream confluences and crossing structures.
<i>Floor Elevations</i>	The elevation of the lowest habitable floor of a structure adjacent to a watercourse of the primary system shall be at least one foot above the base flood elevation associated with the ultimate development condition. However, Table B-2 in Appendix B lists channel reaches where the minimum elevation of the lowest habitable floor of any structure shall be above the base flood elevation by more than one foot. In those cases the minimum floor elevation shall be that shown in Table B-2.

**2. Secondary Drainage System**

<i>Typical Problems</i>	Stormwater problems in the secondary system tend to be localized and scattered throughout both Cities. Typically they result from inadequate provision for streets, storm sewers, and collection channels. Examples include: excessive ponding in streets at low points, excessive storm flow through principal street intersections, overflow of streets, undersized drainage easements, facilities requiring excessive maintenance, and restriction of street uses due to excessive storm flow.
<i>Problem Causes</i>	Causes of problems in the secondary drainage system are listed as follows: <ul style="list-style-type: none"><li>• Inadequate capacity for design flows.</li><li>• Inadequate allowance for increases in storm flow due to future development.</li><li>• No provision for containing and controlling (within designated easements or right of way) the discharge from the 100 year rainfall event under ultimate development conditions.</li><li>• Failure to control discharge from new developments that exceeds the capacity of the receiving secondary system, existing or proposed.</li></ul>
<i>Damage or Nuisances</i>	The results are creation of nuisance problems and situations where damage to public and private property can occur. Remedial measures may be very difficult to achieve, and may range from expensive public improvement projects to situations where remedies are infeasible from a practical standpoint.
<i>Drainage By Design</i>	The policy of both Cities is to avoid formation of these problems through efforts at the design and development stage. Central to this strategy are the performance standards for drainage design contained in these Guidelines, including the “conveyance pathway” concept for containing the base flood discharge.
<i>Performance Criteria</i>	Based on this policy, performance criteria are set for design rainfall events. The emphasis at the performance level is to mitigate the nuisance aspect of storm drainage. An example of a performance standard would be: “design the street and attendant drainage system to carry the discharge from a ten-year rainfall event leaving an area approximately the width of one lane at the center free of any water flow”. These Guidelines contain similar performance standards for various parts of the secondary and primary systems.
<i>Conveyance Pathways</i>	The secondary system is to be evaluated and designed for the stormwater conditions that will result for storms up to the magnitude of the 100-year rainfall event based on ultimate development within the applicable basin. From the location where storm flow is first introduced into a public easement or right of way near the upper end of any basin, a “conveyance pathway” shall be identified and provided to a

discharge point at a main channel of the primary system. The designated “conveyance pathway” must follow or provide clearly identifiable watercourses. Needs for easements or ROW for conveyance pathways are to be assessed per the provisions of Paragraphs E and F of this Section. The purpose of providing for the 100-year storm level is to prevent the creation of situations hazardous to life, or harmful to public and private property. Accordingly, a major emphasis is on deliberately confining storm flow to designated conveyance pathways.

*Watershed Diversion* Generally stormwater emitting from land drained by one named regulatory watercourse of the primary system shall not be diverted to drain into a different named regulatory watercourse of the primary system.

### **3. Detention / Mitigation**

*Detention Purposes* Detention is an important mitigation measure. It can be used effectively for either or both of two fundamental purposes. As a tool for watershed management, it can be deployed with other features to minimize potential flooding along major watercourse(s). It can also be used to manage how stormflow is discharged from a property to adjacent properties. Thus, it can be an integral part of stormflow conveyance in route to the primary system or to a tributary thereof. Both are legitimate reasons for using detention facilities and any one detention facility might work toward both purposes, depending on its location in a watershed. The functional purposes for detention are further defined in foregoing Paragraph B3-b of this Section.

#### **a. Detention Requirements**

*Right Uses* For optimum results detention facilities must be deployed for the right reasons at the right locations. It is the intent of these Guidelines to stipulate the conditions under which detention must be used and why. These Guidelines are not intended to preclude the use of detention at locations where qualified engineers may deem it to be beneficial. Nevertheless, where detention is required by these Guidelines designed facilities must meet the criteria stipulated herein.

*Peak Flow Regulated* Where detention facilities are required, peak stormflow rates from a project area resulting from the two (2), ten (10), twenty-five (25), and one hundred (100) year storm frequency events shall not be increased at any point of discharge. Regulation of peak flows to allowable levels, as determined by the provisions of these Guidelines, shall be achieved by storage facilities on, or away from, a project area, or by participation in an approved Regional Stormwater Management Program.

**b. Detention Facilities May Be Optional***Detention Limited*

At the discretion of the City Engineer, land development activity is not subject to the stormwater detention requirements of these Guidelines if one or more of the four conditions listed in Sub-paragraphs 3-b(1) through 3-b(4) before are satisfied, and an engineer registered in the State of Texas submits a signed, sealed, and dated letter addressed to the City Engineer, stating the following without qualification:

*"I have conducted a topographic review and field investigation of the existing and proposed flow patterns for stormwater runoff from (name of subdivision or site project) to the main stem of (name of creek). At build-out conditions allowable by zoning, restrictive covenant, or plat note, the stormwater flows from the subject subdivision or site project will not cause any increase in flooding conditions to the interior of existing building structures, including basement areas, for storms of magnitude up through the 100-year event":*

(1). Adjacent to Primary System

Any development adjacent to the Primary System may demonstrate that detention is not beneficial to the system with an engineering timing analysis. The analysis should include all upstream development broken into basins of size similar to the development being studied and carried downstream until the development represents less than 2% of the total drainage basin.

(2). One Existing Lot

The proposed development project involves one single existing\* legal lot that is limited to detached single-family land use by zoning, restrictive covenant, or plat note.

(3). Small Lot

The size of an existing\* platted lot is equal to or less than one (1) acre for commercial use, or two (2) acres for detached single family use.

(4). Draining to Designated Streams

At locations included in the drainage watersheds of certain streams stipulated as not requiring detention in Table B-2 in Appendix B, provided Type 2 Detention is not needed for managing property-to-property stormflow.

\* Existing platted lot as used above shall be defined as legal lots of record prior to January 2007.

**4. Water Quality***Concurrent Objectives*

The intent of these Guidelines is to cause development of stormwater management facilities that effectively collect and convey stormflow without causing water damage impacts on life and property. A concurrent objective is to achieve facilities that minimize any adverse

affect(s) on the quality of water conveyed into natural waterways that traverse and/or drain the Cities.

*Water Quality Matters*

It is important that water quality considerations be integral to all aspects of planning, designing, and constructing any facilities regulated by these Guidelines. When design alternatives are at option, the preferred design will be that offering better water quality characteristics for near-term and long-term conditions, as well as during construction, provided the public safety objectives of these Guidelines are not jeopardized.

*Tradeoffs*

Where tradeoffs are faced between public safety and enhanced water quality in any design, greater favor shall usually be afforded to public safety by the designer. However, consistent with applicable State and Federal regulatory requirements, the City Engineer, or his/her designee, may opt to require greater attention to water quality. All information necessary to such decisions shall be the responsibility of property owners (or applicants) proposing the affective land development project(s).

### 5. Master Drainage Plans

*Plan Consistency*

All land development projects and site re-development projects subject to the provisions of these guidelines must demonstrate that plans for managing the stormflow expected to emit from the project(s) are consistent with the City's Master Drainage Plan, or with any applicable publicly approved Watershed management master plan.

## D. Extent of Design

### 1. Threshold for Engineered Design

*Limited Exemptions*

For purposes of these Guidelines, some land development projects may be exempted from requirements for drainage plans designed by a licensed engineer and approved by the Cities. However, in designated FEMA floodplain areas no construction of any kind, including clearing, grubbing or earthwork, may begin without fully approved engineering studies. Likewise, this provision shall not be construed to obviate any requirements of the Texas Professional Engineering Practices Act regarding engineering of facilities to be constructed for public use.

*Possible Exemptions*

Developments of the general nature listed below may be exempted from designs conforming with provisions of these Guidelines after appropriate review and approval by the City Engineer or his/her designee.

- A small lot (existing prior to 2007) less than one acre in size that does not receive stormflow from adjacent or nearby land areas.

- A platted lot (existing prior to 2007) set aside for construction of one detached single family residential unit.
- Any platted lot (existing prior to 2007) less than one acre in size for which adequate stormwater management provisions can be administered through building permit requirements.
- Where, in the judgment of the City Engineer, development of a proposed project on a platted lot will have no appreciable down-stream effect.

### 2. Study Limits

#### *Analysis Limits*

Engineering for assessment of conditions resulting from a stormwater project shall include the **project area**, **above-project area(s)**, and **pathway area(s)** as necessary, and must extend upstream and/or downstream along designated **conveyance pathways** to a point where the applicant (or his engineer) can demonstrate to the City Engineer's satisfaction that there are no appreciable drainage effects caused by the proposed project. Downstream or upstream of these points the minimum responsibility of the project engineer is to merely document the location of the "conveyance pathway" to limits otherwise specified in these Guidelines.

### 3. Special / Alternate Designs

#### a. City Engineer Approval

#### *Equivalent Safe Design*

The City Engineer may, upon request, approve an alternate design or construction methodology that differs from the requirements in these Guidelines if the City Engineer determines that:

- (1). The alternate design or construction methodology is equivalent or superior to the design that would result from using these Guidelines, and
- (2). The alternate design or construction methodology is sufficient to ensure public health and safety.

#### b. Substantiation of Alternate Designs

#### *Responsibility*

It shall be the responsibility of the owner's/developer's (applicant's) engineer to substantiate that any proposed alternate design or construction methodology deviating from these Guidelines meets or exceeds designs or construction methodologies promulgated by these Guidelines.

### 4. Applicable Ordinance Requirements

*Design Reviews* Nothing herein shall be construed to conflict with or supersede design review criteria otherwise established in applicable ordinances of the City of Bryan or the City of College Station.

## E. Public Facilities

### 1. Principles For Public / Private Facilities

*Public/Private Mix* Stormwater management involves some combination of private and public facilities occurring on (or across) land, and in easements or ROW, in a mix of public and private holding (or ownership). The two-fold intent of these Guidelines is to regulate all such facilities as necessary to achieve specific objectives, while minimizing regulation where it is not fundamental to meeting those objectives.

*Rural To Urban* Development activities either change the character (or use) of a previously developed site(s), or generally move land from rural to urban conditions. In the later case, storm runoff is necessarily directed into various types of concentrated flow that typically did not previously exist. This can tend to change both how and where flow is delivered to immediately adjacent properties or facilities. Because the new facilities are commonly situated in easements or ROW proposed to be conveyed to a public entity, the process may create a measure of public responsibility where none had previously existed.

*Discharge Options* It is the responsibility of the owner/developer of any development project to properly provide for storm discharge from the project area. Where street or drainage ROW(s) or drainage easement(s) are to be dedicated to the public, and discharge is to drain across neighboring property(ies) before reaching a Named Regulatory Watercourse (or a recognized drainage way serving as a tributary thereof), it shall be the responsibility of the project owner/developer to accomplish one of the two following scenarios, or some combination thereof.

#### a. First Scenario: Establish Drainage Easement(s)

*Receiving Easements* Drainage easements must be established across down stream properties as necessary along identified conveyance pathways. Such easements must be aligned and sized to safely accommodate the design discharge(s) from the project area, and must extend to a Named Regulatory Watercourse (or a tributary thereof). The easement(s) may be conveyed to a private party or to a public entity at the discretion of the City Engineer or her/his designee.

#### b. Second Scenario: Pre-Development Release

*Designed Release(s)* Drainage facilities must be situated and designed so that discharge(s) are delivered to down stream properties with substantially the same



flow characteristics (rate of flow, concentration, velocity, etc.) that existed in pre-development conditions. In addition, discharges are to be released at substantially the same locations that existed in pre-development conditions. Usually, all work necessary to accomplish this must be within the geographic limits of the project area.

## **2. Maintenance Considerations**

<i>A Design Function</i>	All stormwater management projects subject to the provisions of these Guidelines that are to be dedicated to the public shall be designed with adequate provisions for maintenance of the designed facilities, regardless of their nature. Maintainability and access are important design objectives. These two factors must be an integral part of the design considerations for all stormwater facilities. The same principles must apply to the easements and/or right of way within which such facilities are to be placed.
<i>Importance</i>	Where, in the opinion of the City Engineer, design alternatives meet detention, flood level, and water quality criteria promulgated by these Guidelines and other regulatory requirements in essentially an equal manner, the option(s) offering lesser demand for maintenance work will be preferred. Likewise option(s) offering improved access will be preferred.
<i>Justification Data</i>	All information necessary to making such decisions shall be the responsibility of property owners proposing the land development project(s). Changes in proposed designs may be required in order to meet these objectives.

## **3. Easements and Right of Way**

<i>Drainage ROW</i>	Where any part of a project area is traversed by a channel or stream, whether man-made or natural, an easement or drainage right of way (ROW) is to be provided for the watercourse. Likewise ROW is to be provided for drainage ways newly formed by runoff concentration within the project area of subdivision projects. In all cases ROW is required unless easements are specifically approved by the City Engineer. ROW will generally be required unless stormflow is conveyed via underground conduit, in which case easements will be considered.
<i>Uses Limited</i>	The purpose of easements or right of way (ROW) is to provide the necessary space for stormwater flow and for maintenance of drainage facilities. Any uses of such areas that are inconsistent with these purposes are prohibited. Prohibited uses include, but are not limited to, construction of fences or other obstructions, placement of building structures, or any uses that alter the required shape, configuration, or surface treatment needed for stormwater management functions.

### a. Size Parameters

<i>Approvals Needed</i>	Decisions about the necessary alignment and extent of ROW and easements shall be subject to approval by the City Engineer or his/her designee, and shall be based, in part, on drainage information provided by the applicant. Criteria for this determination shall be based on the anticipated amount and spread of stormwater flow, the possibility of increased flow at some time in the future, any concurrent uses to be associated with the designated areas, the space required for the appropriate maintenance equipment and personnel, and the access necessary to conduct maintenance activities.
<i>ROW For Channels</i>	Where a land development project is traversed by a constructed swale, a constructed channel, a natural channel, or a stream, drainage ROW conforming substantially to the limits of such watercourse (plus additional width to accommodate flow from a 100-year frequency event) must be provided. Additional width may be required for maintenance purposes.
<i>Conduit Easements</i>	Where stormwater is to be conveyed in buried conduits, drainage facilities may be situated in drainage or utility easements provided flow from a 100-year frequency event will be wholly contained within the easement.

### b. Minimum Standards

- The following minimum standards shall be used in determining the size and placement of drainage easements and ROW.
- (1). The minimum width of any drainage easement shall be 15 feet.
  - (2). For buried conduit storm sewer, the minimum width for any drainage easement (or ROW) that is not congruent with any other public ROW or easement shall be 15 feet, and the centerline of the storm sewer shall not be closer than five (5) feet to either side of the easement. In addition, the easement or ROW (inclusive of the conduit capacity) must adequately convey the 100-year storm flow.
  - (3). For purposes of maintenance access for improved open channels, the minimum ROW width shall be the design top width of the channel plus an additional 20 feet (five feet along one side and 15 feet along the other side). However, where the design top width of the channel exceeds 30 feet, 15 feet of additional ROW shall be provided on both sides of the design channel width. Where special designs approved under the provisions of Section II, Paragraph C3 of these Guidelines will obviate the need for easements of these widths, smaller or narrower easements will be considered by the City. However, in no case shall adequate provisions for maintenance be seriously compromised.
  - (4). If access to a drainage easement or ROW is not available from public ROW, then an access easement having a width of 15 feet or more

- shall be provided from a public ROW to the easement or ROW containing drainage facilities.
- (5). The width of all easements and ROW shall be sufficient to include areas that will be part of the designated conveyance pathways of the secondary system.
  - (6). The widths of all ROW for the primary system shall be sufficient to cover the designated floodway for the existing base flood as defined by the latest FEMA regulations.

### **F. Private Facilities**

#### **1. Detention Systems**

*Guidelines Apply*

All stormwater detention facilities required by these Guidelines shall be sized, designed, and constructed in conformance with the criteria stipulated herein and elsewhere in City ordinances or regulations, whether to be retained as private facilities or dedicated to the public within an easement or ROW.

#### **2. Conveyance Systems**

*Figure II-2*

The four conditions described in this sub-paragraph are illustrated in Figure II-2.

##### **a. Discharges Received By Private Land or Facilities**

*From Private*

Stormwater conveyance features that will receive discharge only from private land or facilities at ultimate development conditions may be established as private conveyance systems at the discretion of the City Engineer or her/his designee. Design of such facilities in accordance with provisions of these Guidelines is generally at the discretion of the Registered Professional Engineer in charge of the work.

*From Public*

Where stormflow is proposed to discharge from existing or proposed public ROW(s) or easement(s) to private land or facilities it is the responsibility of the owner/developer (or applicant) to assure that the project discharge is compatible with the down stream land and conveyance features. This responsibility must be met as outlined in Paragraph E1-a /or Paragraph E1-b of this Section, or via some combination of the two concepts.

##### **b. Discharges Leaving Private Land or Facilities**

*To Private*

In situations where conveyance facilities that are to be permanently held in private ownership will discharge to conveyance facilities that are likewise to be permanently held in private ownership, the design is generally at the discretion of the Registered Professional Engineer in

charge of the work. At the discretion of the City Engineer or his/her designee, exceptions to this may apply for watershed management purposes.

*To Public*

Where private lands or facilities will discharge to publicly held lands or facilities, whether in fee simple or in easement(s) or ROW(s), the design, configuration, and construction of the upland facilities shall be in conformance with these Guidelines to the extent required by the City Engineer or her/his designee. Likewise, if private land or facilities are to discharge into floodplain areas or tributaries of a Named Regulatory Watercourse without first traversing public easements or ROW or publicly held land, they are subject to application of these Guidelines at the discretion of the City Engineer or his/her designee.

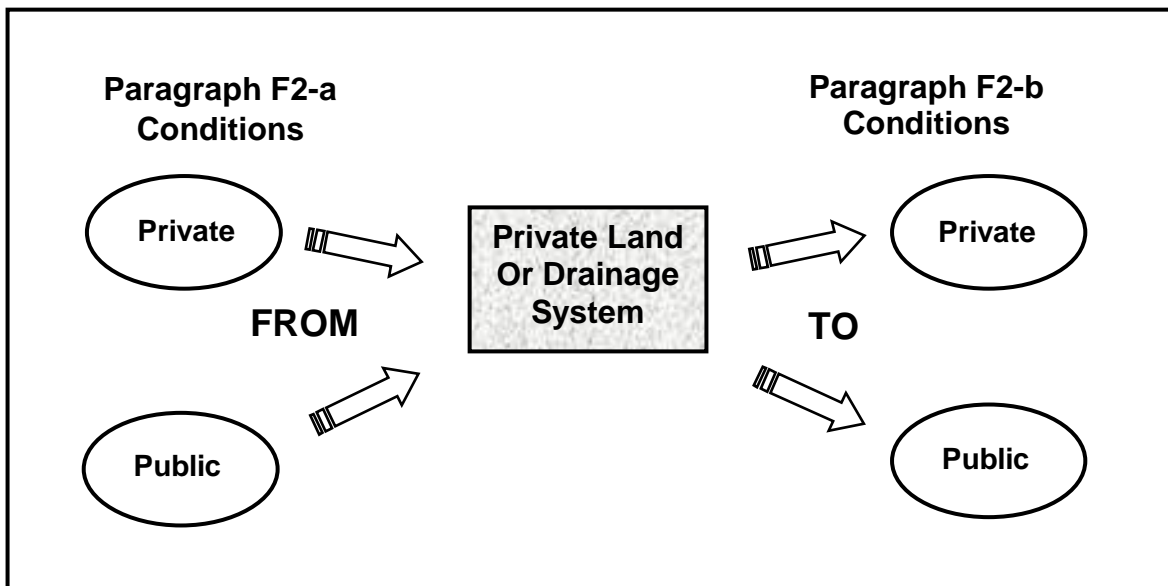

**Figure II-2: Public / Private Conveyance Systems Diagram (Paragraph F2)**

**Section III**  
**Stormwater**  
**Administration**

**Unified**  
**Stormwater**  
**Design Guidelines**

**City of College Station**  
**City of Bryan**

**August 2012**

**A. Permitting Process**

The review process for any drainage plan must be in compliance with requirements of the City of Bryan or the City of College Station as applicable. The following general four-step process is recommended. Depending on the size and hydrologic complexity of the proposed development project, the City may waive one or more steps.

**1. Step One**

This is a Stormwater Planning Conference with the engineering staff of the City. This may be satisfied in conjunction with a “pre-development conference” or other discussions about any number of other regulatory matters that may affect a particular site or proposed subdivision project.

**2. Step Two**

A Preliminary Drainage Plan may be required by the City Engineer or her/his designee following the Stormwater Planning Conference. This step has the benefit of formally documenting the questions and decisions reached during the Stormwater Planning Conference. Its review will allow exploration of all drainage issues that may have bearing on a particular project area and will fully identify the drainage study area (those areas requiring some level of identification and/or analysis). This will facilitate expeditious handling of subsequent steps.

**3. Step Three**

This is submittal of a Drainage Report that fully documents the plan and facilities for managing stormflow of a land development project. At the City’s option this may take the form of an Abbreviated Drainage Plan for smaller projects. In either case this is required for all grading permits, site plans, and subdivision development. The City will provide written notice of review findings pertaining to these reports or plans. This step is completed only when the City has approved the Drainage Report and when engineering plans and specifications for stormwater facilities are “released for construction” by the City.

**4. Step Four**

The fourth step is filing of a development permit application through which a grading or other construction permit(s) may be issued. The application must be completed by the applicant, and approved by the City, prior to clearing and grading operations on any part of a project area.

**B. Stormwater Planning Conference (Step 1)****1. Stormwater Management Concept***Early Discussions*

In order to help guide preparation of a plan consistent with City guidelines and minimize work efforts and review time, the design concept for managing storm flow within and from any proposed land development project shall be discussed with the City prior to the development of any specific design, or preparation of construction plans of any kind for drainage facilities. The hydrologic analysis method(s) to be used must be determined and approved as a result of the discussions. The parties representing the proposed development shall obtain all resources, plans, and references necessary to discuss the items outlined in this section. The conference shall address the following information relative to the proposed development.

**a. General Location Map**

- (1). Roadways within and adjacent to the development
- (2). Primary and Secondary watercourses and all drainage facilities in the vicinity of a proposed project.
- (3). Names, location, and general configuration of surrounding land developments.

**b. Project Area Description**

- (1). Acreage of property(ies)
- (2). Location and size of all project phases, if any.
- (3). Type of land cover (both existing and proposed)
- (4). Name of owner and type of development
- (5). Current zoning status and proposed change, if any
- (6). Any existing natural or man-made topographic features that have the effect of storing or detaining stormwater.

**c. Above-Project Areas**

- (1). Approximate identification of any upland areas that are expected to contribute storm flow to the **project area** (proposed land development project).
- (2). Existing and foreseeable future runoff characteristics of all **above-project areas**.

**d. Conveyance Pathway Areas**

- (1) General identification of downstream conveyance pathways for delivery of runoff from the **project area** to a Primary System watercourse

- (2) Identification of land areas that generally drain to the **conveyance pathway** downstream of the **project area** and the existing runoff characteristics of those areas.

**e. Regulatory Watershed Description**

- (1). Identification of the **Regulatory Watershed(s)** (and Reach thereof) in which the proposed project is located.
- (2). General existing land use characteristics of the **Regulatory Watershed**.
- (3). References to any available earlier drainage studies that addressed any part or all of the land proposed for development
- (4). Applicable Flood Insurance Maps

**f. Drainage Basin Description**

*Thorough Planning*

The report should clearly describe the **Basin(s)** of the **Regulatory Watershed** of which the development project is a part. Drainage patterns on both the **project area** and any applicable **above-project area(s)** must be clearly identified, along with all anticipated impacts on existing and ultimate development. Likewise, the conveyance pathway(s) must be identified along with **pathway areas** (all areas drained by the conveyance pathway).

- (1). General Facility Design
  - a). The report must identify typical drainage patterns and proposed concepts for managing storm flow generated by the proposed project. This shall include sketch delineation of pathways for conveying stormflow within the **drainage study area** and to the Primary Drainage System.
  - b). Considerations for handling runoff from **above-project areas**, and to conveyance **pathway areas** must be discussed.
  - c). The potential need for tables, charts, figures, or drawings to be in the report must be identified.
- (2). Specific Details
  - a). Existing and potential drainage and erosion problems and possible solutions at specific design points must be explored. This is applicable for the entire **drainage study area**, not only the **project area**.
  - b). The potential need for detention/retention storage must be explored, along with the any proposed outlet design concept.
  - c). Aspects of the design important to reasonable maintenance access must be identified.
  - d). Areas to be set aside as drainage easements and/or right of way are to be identified in a general manner.



- e). Needs for bridges or culverts for roadway crossing watercourse(s), including any possible need for skewed crossings or watercourse turns at crossings, must be fully identified.
- f). All required permits must be identified. This includes those required from the US Army Corps of Engineers, the Federal Emergency Management Agency (FEMA), the Texas Natural Resource Conservation Commission (TNRCC), the Texas Commission on Environmental Quality (TCEQ), TxDOT, or any other State or Federal agency.

### e. References

A preliminary list of all criteria, master plans, and technical information applicable to the proposed project must be provided.

## 2. Preliminary Drainage Plan (Report) (Step 2)

### *Report is Key*

Upon completion of the Stormwater Planning Conference (or the pre-development conference) the City Engineer or her/his designee may require the submission of a Preliminary Drainage Report for the purposes of substantiating any assumptions and/or clearing up any questions identified via the conference. A Preliminary Drainage Report (with Drawings) shall be prepared to generally meet the most salient requirements for the Drainage Report but can be in lesser detail. When a Preliminary Drainage Report is required by the City Engineer (or his/her designee) it shall be submitted and approved prior to substantial preparation of construction plans.

## C. Drainage Report Requirements (Step 3)

### 1. Purpose of Report

### *Find Needs*

The purpose of the Drainage Report is to identify and define conceptual solutions to the problems which may occur as a result of the proposed development, on **project areas, on above-project areas**, and along conveyance areas. The Drainage Report must include drawings as necessary to fully and clearly describe the information required by these Guidelines. All reports shall be printed on 8-1/2" x 11" paper, bound together, and submitted in two hard copies and one electronic copy (pdf format). The report shall include a cover letter presenting the proposed design for review, and shall be prepared by a Registered Professional Engineer licensed in Texas. The report shall contain a sheet authenticating its technical accuracy as follows:

### *Work Certification*

*"This report (plan) for the drainage design of (name of development) was prepared by me (or under my supervision) in accordance with provisions of the Bryan/College Station Unified Drainage Design Guidelines*

*for the owners of the property. All licenses and permits required by any and all state and federal regulatory agencies for the proposed drainage improvements have been issued.”*

---

*Licensed Professional Engineer*

*State of Texas No. \_\_\_\_\_*

*(Affix Seal)*

## **2. Abbreviated Drainage Plan**

### **a. Suitability**

In certain situations, consistent with the policies and practices of each City, the owner/developer (or applicant) may provide an Abbreviated Drainage Plan in satisfaction of these Guidelines. This is applicable only to small site plan projects on platted lots, not involving the development of stormwater detention facilities, private or public. Although not precluding involvement of an engineer, the scope of such site projects generally does not involve hydrologic or hydraulic engineering analysis or the design of stormwater management facilities. Subdivision land development projects are specifically excluded from this type of submittal. As a function of the size, location, and hydrologic complexity of a project, the City Engineer or his/her designee may require submittal of an engineered drainage report.

### **b. Submittal Requirements**

An Abbreviated Drainage Report is generally a very simple presentation of how stormwater is to be managed on a small project. At a minimum such a plan must include the information listed below. It must be accompanied by a letter of transmittal requesting approval, and all proposed site features must be subject to inspection via building permit processes.

- A site plan drawn to a standard engineering or architectural scale showing vertical dimensional controls and proposed site grading,
- Finish floor elevations of structures and illustration of how stormwater is to be routed around and away from them,
- Illustration of any flumes, walls, berms, and/or landscaping features proposed for the purpose of managing runoff,
- Documentation of how erosion and sedimentation will be prevented as a permanent part of the project,
- Description of how runoff is to be routed away from the property,

- Measures employed to preclude any negative affects on downstream properties, and
- Measures to preclude any negative effects on public or private watercourses to which runoff will be directed.

### **3. Drainage Report Contents**

*Report Or Summary*

The Drainage Report may be submitted in one of two formats. It may be written in a traditional prose format complete with an executive summary at the beginning, or it may be submitted as a Technical Design Summary. In either format, the report shall be in accordance with the following outline and contain the applicable information stipulated below. The executive summary attendant to a traditional report shall include, at a minimum, the same information as required in Part 1 of a Technical Design Summary, and shall be presented in the same format.

#### **a. General Location and Description of Project Area**

(1). Location

- a). Streets and roadways within and adjacent to the Project Area (proposed land development project)
- b). Named Regulatory Watercourses and facilities
- c). Names of existing or approved developments or plats surrounding the proposed Project Area whether adjoining it, or separated from it by a street (or highway) or watercourse.
- d). Names and location(s) of master plan(s), preliminary plat(s), and/or site plan(s) for adjoining properties that may be in pending status with either City as of the date of the report, to the extent such information is available from local jurisdictions.

(2) Description of Project Area Property

- a). Total acreage of Project Area
- b). Acreage of Project Area proposed for near term and any future phased improvements
- c). Name of property owner(s) and land developer(s) and applicant (s)
- d). Land cover characteristics
- e). Primary and secondary system watercourses within or adjacent to the property
- f). General description of proposed project

**b. Drainage Watershed (s) and Study Area(s)**

- (1) Regulatory Watershed Description
  - a). Reference to Named Regulatory Watercourse planning studies such as flood hazard delineation reports and flood insurance rate maps.
  - b). General existing land use characteristics of the Regulatory Watershed and the applicable Reach(s) thereof.
- (2). Drainage Basin(s) (sub-Watershed) Description
  - a). Identification of drainage flow patterns from above-project areas
  - b). Impact of proposed development on existing and proposed conveyance pathways to Named Regulatory Watercourse(s)
  - c). Description of historic drainage patterns in areas proposed for development
  - d). Description of existing natural or man-made topographic features that have the effect of storing or detaining stormwater within the Project Area.
- (3). Drainage Study Area
  - a). Clear delineation of all of the Project Area (the proposed land development project), all Above-Project Areas contributing, or proposed to contribute, stormflow to the Project Area, and all Conveyance Pathway Areas.
  - b). Existing drainage conditions and flow patterns for all of the proposed Project Area, and for all Above-Project Areas.
- (4). Drainage Plan
  - a). Proposed drainage conditions and flow patterns for all of the proposed Project Area and for all Above-Project Areas contributing stormflow to the Project Area must be shown.
  - b). General review of the Conveyance Pathway(s) and identification of any points along it (them) where capacity limitations are known or suspected to exist.
  - c). General location and size of any proposed detention/retention facilities.
  - d). Identification of the location and type of all collection and conveyance facilities proposed to serve the Project Area.

**c. Drainage Design Criteria**

- (1). The range of design storm flows anticipated at critical points throughout the proposed drainage system must be shown, in addition to how flow will be accommodated at each point. All assumptions and hydrologic parameters must be shown.

- (2). Stormwater Management Criteria Reference(s) and Site Constraints
  - a). Identification of earlier drainage studies for or including the Project Area or any portion of Above-Project Areas that influence, or are influenced by, the selected drainage design.
  - b). Demonstration of how conditions in any Above-Project Area(s) will affect drainage design for the Project Area.
  - c). Explanation of how existing and proposed topographic constraints such as streets, structures, and layout of proposed facilities (including building pads if applicable) will impact plans for managing storm flow.
- (3). Hydrological Parameters
  - a). Documentation for determination of design rainfall
  - b). Identification of runoff calculation method
  - c). Identification of detention discharge and storage calculation method, if any
  - d). Identification of design storm recurrence intervals
- (4). Conveyance System Hydraulic Parameters
  - a). Identification of capacity of various existing and proposed conveyance systems, citing any design or study references used
  - b). Identification of detention/retention outlet type, if any
  - c). Identification and explanation of any drainage facility design criteria not presented in these Guidelines.
- (5). Any criteria, methods, or design techniques that deviate from these Guidelines must be identified and fully justified.

**d. Drainage System Design**

- (1). General Concept
  - a). Identification of anticipated and proposed drainage patterns and the proposed stormflow management concept(s).
  - b). Documentation of compliance with all requirements for managing Above-Project Area runoff in terms of discharge and capacity.
  - c). Documentation of compliance with requirements for analysis and design of conveyance pathways as determined necessary during the pre-development conference or other meetings with the City Engineer or her/his designee.
  - d). Explanation of the content of tables, charts, figures, or drawings presented in the report

- (2). Specific Details
  - a). Descriptions of drainage problems and proposed solutions at specific design points
  - b). Description of detention storage design and outlet design including measures for minimizing erosion at discharge points
  - c). Identification of access ways for maintenance of all proposed stormflow management features, whether to be privately held or conveyed via platting to the City.

**e. Conclusions**

- (1). Statements of compliance with the Bryan/College Station Unified Drainage Design Guidelines.
- (2). Effectiveness of drainage design to control flooding or damage due to design stormflows, including minimization of erosion along conveyance pathways serving the project.
- (3). Explanation of the effectiveness of existing and proposed drainage improvements for controlling discharges of the 2-year, 10-year, 25-year, and 100-year storms, assuming ultimate development conditions within the Drainage Study Area of the proposed land development project.

**f. References**

Reference all criteria, master plans, and technical information applicable to the proposed land development project must be referenced.

**g. Appendices (where applicable)**

- (1). Hydrologic Computations
  - a). Land use assumptions regarding adjacent properties
  - b). Minor and major storm runoff at specific design points
  - c). Runoff computations at specific design points for both existing and ultimate development of all Design Drainage Areas.
  - d). Hydrographs at critical design points
- (2). Hydraulic Computations
  - a). Culvert capacities
  - b). Storm sewer capacity
  - c). Street capacity
  - d). Storm inlet capacity including inlet control rating at connection to storm sewer
  - e). Open channel design
  - f). Detention area/volume capacity and outlet capacity calculations

(3). **Municipal Approvals and Permits**

This appendix to a drainage report is for the purpose of documenting any approvals or permits issued by either City as applicable. Examples include (but are not limited to) zoning, final or preliminary plats, clearing and grading permits, or building permits. The status of all pending requests is to be documented as well as any issued approvals or permits. Presentation of this information may take the form of a simple list that includes the pertinent identifying data such as case codes, property identification, applicant, and application/action dates. Alternatively, photocopies of application and/or approval documents may be included. Specific requirements for this information should be addressed during the stormwater planning conference.

(4). **Non-Municipal Permits**

- a). Issued or pending permits regarding FEMA-designated Regulatory Watercourses.
- b). Issued or pending permits required by the US Corps of Engineers
- c). Issued or pending permits regarding water quality or endangered species in stormwater management or land development activities, whether required by units of State or Federal Government.
- d). Easements or statements of technical reviews required to satisfy other governmental units including TxDOT, Brazos County, and the Texas A& M University System.

#### **4. Drainage Report Drawings**

**a. Sheet # 1 – General Location Map**

- (1). Depict drainage flows entering and leaving the Project Area
- (2). Identify construction along drainage ways, including all areas where natural ground cover is to be removed or significantly disturbed
- (3). Illustrate general drainage flow within entire Drainage Study Area
- (4). Draw at a scale of between 1' = 500' and 1" = 2000'

**b. Sheet #2 – Floodplain Information**

- (1). Copies of existing 100-year floodplain maps showing the location and approximate boundaries of the land development project.

**c. Sheet #3 – Drainage Plan Maps(s) Showing:**

- (1). Complete Drainage Study Area boundary including: Above-Project Areas and how stormwater flows from them to the Project Area, Conveyance Pathways draining the Project Area, and Pathway Areas.

- (2). Entire Project Area, including depiction of areas proposed for near term construction activity, at a standard engineering scale providing complete legibility and on drawings not exceeding 24 inches by 36 inches in size.
- (3). Existing and proposed contours at maximum intervals of two feet
- (4). Property lines and easements with purposes noted
- (5). Existing and proposed streets and highways including ROW lines
- (6). Existing drainage facilities, roadside ditches, drainage ways, gutter flow directions, and culverts. All pertinent information such as material, size, shape, slope, and location shall also be included.
- (7). Boundaries of all Design Drainage Areas.
- (8). Proposed type of street flow (roadside ditch and/or gutter flow) and flow directions.
- (9). Plan and profile of proposed storm sewers and open drainage ways, including inlets, manholes, culverts, junction structures, and other appurtenances.
- (10). Clear indication of changes in pipe size in storm sewer system
- (11). Proposed outfall point(s) for runoff from areas proposed for construction and facilities to convey flows along proposed Conveyance Pathways to outfall points in the system of Named Regulatory Watercourses.
- (12). Routing and accumulation of stormflow at various critical points for the minor storm runoff
- (13). Path(s) chosen for computation of time-of-concentration
- (14). Location of detention/retention storage facilities and outlet works
- (15). Location and elevations of all documented floodplains affecting the properties proposed for land development.
- (16). Location and elevations of all existing and proposed utilities affected by or affecting the drainage design.
- (17). Routing of any drainage that must flow through the development project from Above-Project Areas.
- (18). Finished floor elevations of existing structures in flood plains adjacent to Primary or Secondary watercourses.
- (19). Existing 100-year water surface elevations for each lot or building site in flood plains adjacent to Primary or Secondary watercourses.
- (20). Notation about any off-project features influencing the proposed land development



**D. Construction Drawings and Specifications****1. Compliance With Drainage Report***Plans Fulfill Report*

Where drainage improvements are to be constructed they must be in accordance with the approved Drainage Report. Construction plans and specifications must demonstrate how and where the stormwater management concepts of the Drainage Report will be implemented. Plans on sheets no larger than 24 inches by 36 inches, together with any specifications not consistent with B-CS Technical Specifications, shall be submitted for review and approval prior to construction. Plans (plan and profile sheets) and specifications for the drainage improvements will include all of the following information as applicable.

**a. Storm Sewer Systems**

- Line sizes, alignments, flow line elevations
- Junction boxes, man holes
- Inlets and outlets

**b. Culverts**

- Size, alignment, flow line elevations
- End treatments
- Inlet and outlet protection

**c. Open Watercourses**

- Channel alignment, section, and flow line elevations
- Sizes and flow lines of ditches and swales
- Surface treatments

**d. Detention Facilities**

- Pond size, placement, grading and elevations
- Pond outlets, and outfall treatments
- Pilot channel alignment, grade, and section (when used)
- Landscaping

**e. Related Structures / Facilities**

- Erosion control features
- Provisions for maintenance access
- ROW and/or easements, both public and private as applicable

**f. Flood Information**

- Finished floor elevations of buildings adjacent to stormwater facilities
- 100-year water surface elevations

**g. Approvals**

- Engineer's certification
- Action by the respective City to "release for construction" as evidenced by titles and signatures of required City officials

**2. Compliance With Design Guidelines (Step 4)***Thorough Plans*

The information presented by the drawings and specifications shall be in accordance with sound engineering principles, the design parameters herein, and requirements for subdivision design stipulated by the City of Bryan or City of College Station, as applicable. Construction documents shall include geometric, dimensional, structural, foundation, bedding, hydraulic, geotechnical, ecological, landscaping, erosion control, project limits, and other details as needed to construct the project. The approved Drainage Report shall be included as part of the construction documents for all facilities affected by the drainage plan.

**E. Record Drawings****1. Required Plans***Before Acceptance*

Plans documenting all constructed public drainage facilities and private detention/retention ponds ("Record Drawings") shall be submitted to the city upon completion of the construction work. These documents (on 24" by 36" three-mil mylar) must be received and deemed consistent with all applicable regulations by the City before the improvements will be accepted. The construction drawings are acceptable as Record Drawings provided construction has not significantly deviated from them.

**2. Engineering Attestation***Accuracy Of Plans*

A registered professional engineer licensed to practice in Texas must attest that the "Record Drawings" provided in satisfaction of the forgoing paragraph are a reasonably accurate representation of the location and characteristics of public storm drainage facilities and all detention facilities (private or public) as actually constructed. The center line alignment within plus or minus six (6) inches, and size of buried conveyance conduit shall be shown. Information about the size, elevation, and conveyance attributes of detention outlet structures and spillways shall be shown. The storage capacity and perimeter elevations of public and private detention ponds shall be shown. Attestation shall be via the following statement affixed with signature and seal to each sheet of the Record Drawings:

*“I hereby attest that I am familiar with the approved drainage plan and associated construction drawings and furthermore, attest that the drainage facilities have been constructed within dimensional tolerances prescribed by the Bryan & College Station Unified Stormwater Design Guidelines and in accordance with the approved construction plans or amendments thereto approved by the City of*

\_\_\_\_\_.”  
(Bryan or College Station)

\_\_\_\_\_  
*Licensed Professional Engineer*  
State of Texas No. \_\_\_\_\_

*(affix seal)*

**3. Construction Attestation**

*Full Construction*

Each plan and profile sheet of materials presented as Record Drawings shall bear a certification from the general contractor as follows:

*“I certify that the subdivision improvements shown on this sheet were actually built, and that said improvements are substantially as shown hereon. I further certify, to the best of my knowledge, that the materials of construction and sizes of manufactured items, if any, are stated correctly hereon”*

\_\_\_\_\_  
*General Contractor*

**Section IV**  
**Related Permitting**

**Unified  
Stormwater  
Design Guidelines**

**City of College Station  
City of Bryan**

**August 2012**

### A. FEMA-Designated Floodplains

#### 1. Regulatory Floodplains

*Named Watercourses* Based on long experience with helping offset the costs suffered by flood victims, The Federal Emergency Management Administration (FEMA) has developed a flood insurance program centered on the concept of floodplain management. Based on a series of engineering studies FEMA has mapped flood-prone areas along principal watercourses and their tributaries in urban areas nationwide. Termed “Flood Insurance Rate Maps”, these indicate areas where citizens may obtain flood insurance at favorable rates due to FEMA subsidies. For purposes of these Guidelines the FEMA-designated watercourses and their tributaries are designated as the “Named Regulatory Watercourses” of the Cities. The pertinent watercourses are identified in Table B-1, Appendix B.

*Floodplains* The Cities administer FEMA regulation of the floodplains of the Named Regulatory Watercourses as necessary to ensure the availability of affordable flood insurance to area citizens.

#### 2. Regulations

*Minimize Flooding* FEMA has established certain criteria that must be met by the Cities along specific watercourses. The purpose is to minimizing flooding, so use of “flood fringe” areas is purposely limited. Complex criteria affect both mapped areas and, in some instances, areas that are not yet fully mapped based on engineering studies. Where a land development project or construction of any kind will have the effect of limiting the cross sectional area of a FEMA-designated watercourse, engineering studies are necessary to determine the hydraulic effects, and to assess whether flood stage water surface elevations will be affected outside of allowable criteria. Where the upper reaches of a FEMA-designated watercourse are not adequately mapped, engineering studies will be necessary to do so.

#### 3. Managing Encroachment

*Watersheds* Development of lands along FEMA-designated watercourses may involve the proposed use of “flood fringe” areas, overbank areas not usually involved with conveyance of stormwater during low flow conditions. Use of such areas is considered “encroachment” into regulated floodplains, and is therefore, limited. Encroachments generally have the affect of restricting the cross sectional area of a watercourse, so the objective is to avoid causing water surface elevations at flood stage to rise above certain predetermined levels as necessary to the characteristics of each watercourse.

### 4. Procedures

*Other Sections* The possible need for engaging FEMA in review and approval of flood studies or crossings of FEMA-designated watercourses must be identified at the Stormwater Planning Conference outlined in Section III of these Guidelines. Different levels of FEMA approval are required as a function of the proposed activity and its potential impact on flood-prone areas. The approval appropriate to a project must be obtained and documented to the City Engineer's satisfaction before authorization will be given to start construction.

*Encroachments* The rationale for determining the extent of allowable encroachment and specific limitations are stipulated in Sections V and VI of these Guidelines. Both general criteria and criteria applicable to specific watercourses are included. Associated information is included in the Appendix.

### B. Stormwater Quality

*Permits If Needed* There are a number of national and state regulations that have bearing on the quality of stormwater emitted from land development projects in the Cities. These are principally focused on efforts to minimize the amount of sediments and pollutants carried into streams and waterways by storm runoff. Specific permitting requirements that may, from time to time, be required under any of the legislative provisions listed below must be met by owners/developers (or applicants) of land development projects. Proof that required permits have been issued by the appropriate authority must be provided before construction will be authorized by the City.

- Section 10 US Harbors and Rivers Act as administered by the US Army Corps of Engineers (USACE).
- Section 404 of the US Clean Water Act as administered cooperatively by the US Environmental Protection Agency (EPA) and the USACE.
- Section 401 of the US Clean Water Act as administered by the EPA.
- Section 402 of the US Clean Water Act as administered by the EPA in cooperation with the Texas Commission on Environmental Quality (TCEQ).
- Texas Administrative Code (30 TAC, Chapter 319) as administered by the TCEQ pursuant to the Texas Pollutant Discharge Elimination Program in cooperation with the EPA's Section 402 regulation of small MS4s.

*Sections Apply* More specific information about these regulatory requirements is included in the appropriate sections of these Guidelines. Section 402 provisions about Stormwater Pollution Prevention Plans (SW3Ps) are addressed in Section VII, Erosion and Sedimentation. Section VIII,

## **SECTION IV**

### **RELATED PERMITTING**

Water Quality, provides more information about all of the regulatory citations listed above. Appendix E outlines several Best Management Practices (BMPs) that might be used in minimizing the pollutants discharged from a land development project through storm runoff.

#### **C. Governmental Entities In Bryan-College Station Region**

*Planning Required*

If a land development project of any size or complexity might possibly involve one or more of the entities listed in this Paragraph (Section III, Paragraph C), that potential must be made known as early as possible in the development review process. Ideally the needed coordination and approvals will be fully discussed during the Stormwater Planning Conference outlined in Section III of these Guidelines. At the very least, such coordination must be identified as an open matter at that time and fully addressed in the project Drainage Report.

##### **1. Brazos County**

*Approvals Required*

Certain land development projects may directly or indirectly involve Brazos County Government. This may include site construction projects as well as subdivisions, and includes the creation of public drainage easements or ROW. Approvals by the office of the County Engineer must be substantiated in the form of letters or any documentation acceptable to the County Engineer and the City Engineer, or their respective designees.

*Site Projects*

Any site development project that is wholly or partially in the corporate limits of the City is subject to these Guidelines. Where a project will discharge stormwater directly or indirectly into roadway areas administered by Brazos County, it will be necessary for the project owner/developer (or applicant) to secure the necessary approvals by the office of the County Engineer, or his/her designee. Likewise, if stormwater is to be discharged into a drainage way of any character that is maintained or administered by the office of the County Engineer, approvals must be obtained. Approvals must be substantiated before site drainage plans will be approved by the City.

*Subdivisions*

Subdivisions are commonly proposed within the corporate limits or the Extra Territorial Jurisdiction (ETJ) of the City, and may be partially in both. Also, a subdivision project area may be partially in a City's ETJ and extend outside of the ETJ. Under any of these conditions stormwater facilities may be planned to discharge into roadside ditches or watercourses that are under the jurisdiction of Brazos County. In such circumstances County roadway facilities may be affected within or adjacent to the project area, or downstream thereof. For this reason the project owner/developer (or applicant) must secure the necessary approvals by the office of the County Engineer, or his/her designee. City approval of plats is subject to this approval after full coordination between the offices of the City Engineer and the County Engineer.

### 2. Texas Department of Transportation (TxDOT)

*TxDOT Facilities* Any land development project that is adjacent to or astride a highway route administered by TxDOT must be fully coordinated with the office of the TxDOT Area Engineer or his/her designee. All ROW and drainage easements under TxDOT jurisdiction must be fully identified, as well as any stormwater discharge(s) received from TxDOT facilities. Likewise any proposed discharges to TxDOT facilities or easements must be identified in detail.

*Documented Action* Evidence of adequate coordination with TxDOT must be provided to the City Engineer or her/his designee. Documentation of the necessary coordination must be to the mutual satisfaction of the offices of the TxDOT Area Engineer and the City Engineer. Approval of site construction projects and final plats is subject to satisfaction of this requirement by the project owner/developer (or applicant).

### 3. Brazos River Authority

*State Agency* The Brazos River Authority is a State agency charged with overall management of the water resources of the entire Brazos River Watershed stretching from far west Texas to the Gulf of Mexico. The Agency's focus is on water treatment and sewage treatment services for communities along the river's route. Its mission includes development and management of several water and flood control reservoirs.

*Limited Role* During recent years the Agency has been given a broader role in support of the TCEQ's water quality mission. This largely parallels the Agency's other activities so it is focused on effluent point sources like sewage treatment and industrial processing enterprises. The Agency has no known role in reviewing or permitting stormwater facilities proposed in land development projects in the Bryan-College Station Region. The one possible exception would be in situations where permanent water impoundment is proposed directly on tributaries to the Brazos River. The Agency should be contacted as early as possible if impoundment is proposed in order to determine the extent of permitting that might be required, if any. Any associated permitting requirements must be met by the project owner/developer (or applicant). Documentation thereof must be provided to the office of the City Engineer before design plans will be accepted for construction.



### 4. Texas A&M University System

*Land Owner*

The TAMU System (TAMUS) has no authority over land development activities outside of its own land ownership. However, it must be accorded all of the rights and most (if not all) of the responsibilities ascribed to property owners by Texas surface water law. Stormwater discharges by the TAMUS into facilities under jurisdiction of the City will be directly coordinated between the TAMUS and the City.

*Documented Action*

Stormwater discharges to or through land owned by the TAMUS must be coordinated with the System Facilities Office located in College Station. Where a land development project proposes to discharge stormwater onto or through TAMUS properties it will be the responsibility of the owner/developer (applicant) to handle that coordination with the TAMUS and to substantiate the results to the City Engineer or his/her designee. The coordination must be documented to the satisfaction of the City Engineer or her/his designee before site or subdivision development projects can be approved.

**Section V**  
**Hydrology**

**Unified  
Stormwater  
Design Guidelines**

**City of College Station  
City of Bryan**

**August 2012**

**A. Introduction***Analysis Methods*

The two types of hydrologic analyses most often required are the computation of the peak discharge at a specific location and the computation of a hydrograph at a specific location. Two methods are recommended for computation of peak discharges and two methods are recommended for computation of hydrographs. The application of these methods is a function of the purpose of the hydrologic examination and the size of the Design Drainage Areas being examined as outlined in these Guidelines. Other methods of proven use may be submitted to the City for approval. It is highly recommended that approval be obtained before significant hydrologic work is accomplished for a project.

**B. Stormwater Runoff Calculation Methods****1. The Rational Formula****a. Variables**

The formula shall be expressed as:

$$Q = ciA$$

Where the variables are defined below.

“**Q**” is the discharge in exact units of acre-inches per hour and accepted to be equivalent to units of cubic feet per second (cfs). This value is taken as the peak or highest discharge expected at a designated design point.

“**c**” is a coefficient, having no units, that represents the average runoff characteristics of the land cover within the drainage area delineated for a designated design point.

“**i**” is the rainfall intensity in units of inches per hour (in/hr.).

“**A**” is the area of land in acres that contributes stormwater runoff that passes through or at a designated design point.

**(1). Intensity-Duration-Frequency Relationship**

Rainfall intensity ( **i** ) is defined as the average rate of rainfall in inches per hour. It can be determined for storms of various return frequencies as commonly represented by several intensity-duration-frequency (IDF) curves in graphical form. Duration ranges from ten minutes to 24 hours, and is assumed to be the time of concentration. Rainfall intensities may be determined from (IDF) curves or from the equations

presented in Table C-1, Appendix C. These equations approximate the IDF curves within a reasonable margin of error. For the Rational Method, the critical rainfall intensity is that having a duration equal to the time of concentration of the design drainage area. Determination of time of concentration ( $t_c$ ) is discussed in Paragraph B1-a(3) below.

2). Runoff Coefficients

a). Tables C-2 and C-3 in Appendix C shall be used to select the runoff coefficient “**c**” for the appropriate land cover and land use. Linear interpolation shall be used to choose specific values within the ranges given.

b). For areas that consist of different types of land cover or land use, a weighted average runoff coefficient shall be computed using the following equation.

$$c = \frac{c_1 A_1 + c_2 A_2 + \dots c_x A_x}{A}$$

Where:

**A** = **A**<sub>1</sub> + **A**<sub>2</sub> + ... = **A**<sub>x</sub> the total drainage area,

**c**<sub>1</sub>, **c**<sub>2</sub>, ... **c**<sub>x</sub> are the runoff coefficients for sub-areas,

**A**<sub>1</sub>, **A**<sub>2</sub>, ... **A**<sub>x</sub> are the areas of land cover or land use that correspond to the runoff coefficient **c**<sub>1</sub>, **c**<sub>2</sub>, ... and **c**<sub>x</sub> respectively, and

**c** is the runoff coefficient for use in the formula for the Rational Method.

c). The runoff coefficient “**c**” shall be determined using the “land use” when using the rational formula to compute the peak discharges within or from specific sites and developments.

d). Referring to Tables C-2 and C-3 in Appendix C, the runoff coefficient “**c**” may be determined from the “land use” when using the rational formula to compute the peak discharge from more than one site or development.

(3). Time of Concentration

a) Principles --Time of Concentration ( $t_c$ ) is the theoretical time required for a drop of rain to travel from the most hydraulically remote point in a Design Drainage Area to a point where storm flow is to be determined (the point of calculation). Assuming rainfall is uniform over time and uniform on the watershed, the time of concentration is the first moment when the entire Design Drainage Area is contributing to the runoff at the point of calculation, because during that time all other parts of the Design Drainage Area will also be contributing flow to that point. This is fundamental to estimating total flow at the point of

calculation based on the assumption of uniform rainfall over time, as accomplished using the Rational Method.

<i>Hydrograph Peak</i>	When used within computations using shaped unit hydrographs, the time of concentration is used (usually indirectly) to determine the timing of the peak of the hydrograph in relation to the beginning of the storm event.
<i>Watershed Factors</i>	The length of time will depend on several characteristics of the Design Drainage Area. Slope, ground cover, degree of concentration, and the antecedent moisture content of the soil are principle among these. When such characteristics are not entirely uniform it is necessary to assess the composite effects of differing characteristics found in parts of the Design Drainage Area. Because hydraulic equations are rarely linear in nature, the averaging of characteristics, such as slope, can readily create inaccuracies. Likewise, multiple variations in characteristics of the Design Drainage Area can cause compounding of inaccuracies, thus generating unreliable results.
<i>Segment Analyses</i>	In order to ensure accurate results, each segment having different characteristics must be calculated independently, and the resulting times then added to obtain the overall time of concentration ( $T_c$ ). The time of concentration should be determined for each segment of significantly differing slope, surface roughness, and/or cross sectional area. Values of velocity ( $v$ ) for determining ( $t_c$ ) for each segment are given in Table C-4 in Appendix C. The time needed for runoff to flow through each of these segments is known as Travel Time ( $T_t$ ).
<i>Flow Characteristics</i>	<p>To expedite these calculations, formulas have been developed to estimate travel time by factoring out certain variables from the basic hydraulic equations. Some are assumed to be effective for the initial sheet flow state where the runoff is spread very thinly over a relatively wide area. Some equations are applied to a condition known as 'shallow concentrated flow' in which the runoff is not in a uniform sheet, but is concentrated in an irregular manner not allowing determination of flow cross sections. Where flow is channelized in a reasonably uniform manner allowing use of cross section information, Manning's Equation is normally used to determine velocity, and thus time of travel.</p> <p><u>b). Analysis Criteria</u> -- For purposes of consistency, these Guidelines provide a single set of equations for the estimation of Time of Concentration. These equations and related criteria are adapted directly from the TR-55 manual published in 1986 by the Soils Conservation Service (now the Natural Resources Conservation Service). Other accepted methods may be submitted and considered as special designs.</p> <p><u>Initial Sheet Flow:</u> For initial flow areas, which are both uniform and planar, Manning's Kinematic equation (shown below as published by Overton and Meadows, 1976) should be used. Its use is based on the</p>

four assumptions listed below. In no case should a length exceeding 300 feet be considered.

- Shallow uniform steady flow
- Constant rainfall intensity
- Rain duration of 24 hours
- Infiltration does not impact travel time

$$T_t = \frac{0.007(nL)^{0.8}}{(P_i)^{0.5} S^{0.4}}$$

Where:

**T<sub>t</sub>** = Travel time (hours)

**n** = Mannings' roughness coefficient for sheet flow (Table C-5, Appendix C).

**L** = Overland flow distance (feet)

**P<sub>i</sub>** = Recurrence interval for the 24-hour rainfall depth (inches) in the *i*<sup>th</sup> year (Table C-6, Appendix C)

**S** = Slope of land (feet per foot)

Shallow Concentrated Flow: For reaches where the flow is no longer uniform and planar, and a flow cross section cannot be determined, the equation for shallow concentrated flow should be used. This equation estimates flow velocity, which can be translated into travel time.

$$T = \frac{D}{60V}$$

Where:

**T** = Travel time (minutes)

**D** = Flow distance (feet), and

**V** = Average velocity of runoff (feet per second)

Channel Flow: Where a flow cross section can be determined, Manning's Equation should be used with appropriate factors for the segment being analyzed.

In any case the time of concentration need not be taken as being less than 10 minutes.

#### b. Assumptions and Limitations

- (1). The Rational Formula shall only be used to estimate peak discharges at specific designated design points.

- (2). The contributing area “A” of runoff shall not exceed 50 acres.

## **2. Natural Resource Conservation Service (formerly SCS) Methods**

### **a. Hydrology Principles**

“SCS” No. 55

Technical Release No. 55 – Urban Hydrology For Small Watersheds forms the basis for examination of watersheds considered large as regulated by these Guidelines. These “SCS” methods are empirically derived relationships that use precipitation, land cover, and physical characteristics of Design Drainage Areas to calculate runoff amounts, peak discharges, and hydrographs. Of the various methods available, the following two are adopted for use:

- (1). Chart Method – used to determine the peak stormwater discharges and the effect of development on those peak discharges at a designated design location.
- (2). Tabular Method – used to determine a hydrograph of stormwater discharges at a designated design location.

### **b. Variables**

- (1). 24 Hour rainfall depths for the Bryan-College Station area (Table C-6 in Appendix C) shall be used to select the rainfall depth for selected storm return periods. This value shall be used for the variable “P” as input to all equations, graphs, and tables as applicable. A Type III rainfall distribution developed in 1990 shall be used to determine incremental totals.
- (2). Hydrologic Land Cover Parameters (SCS Curve Numbers)
  - a) The engineer shall determine the land cover parameters based on soil type from the county soils maps and natural vegetation only. All development shall be input as impervious percentage per Table C-7.
- (3). Determination of Peak Discharges – The TR-55 Chart Method
  - a). Calculations must include the appropriate factors and modifications for the shape and slope of the Design Drainage Area, and urbanization (percent of impervious area and percent of hydraulic length modified).
  - b). Where a Design Drainage Area consists of several types of land cover and/or land use, a composite percent of impervious area shall be determined using the same methodology outlined in Paragraph B1-a-(2)-b) of this Section.
- (4). Determination of Time of Concentration

One of two methods shall be used, the “Lag Method” or the “Upland Method”. Details on the use of both are available in “TR-55”.

**c. Assumptions and Limitations**

- (1). The accepted methods from Technical Release No. 55 are for use in determining stormwater discharges and hydrographs in the Secondary Drainage System only.
- (2). Application of these methods shall be in strict conformance with the instructions and recommendations given in Technical Release No.55 and the latest updates and revisions issued by the Natural Resource Conservation Service (formerly SCS), except as superseded or altered by the requirements of this section.
- (3). The Design Drainage Area for application of these methods shall not exceed 2000 acres.

**3. Hydrograph Methodology****a. Methods***Hydrographs*

Two methods of determining a hydrograph are accepted for use. These are the Tabular Method of NRCS (formerly SCS) Technical Release No. 55, and the NRCS (formerly SCS) Dimensionless Unit Hydrograph method. The principal aspects of each are outlined below.

- (1). Tabular Method of NRCS (SCS) Technical Release No. 55 --The hydrograph is computed by an empirical method that relates drainage area, land use, and time of concentration.
- (2). NRCS (SCS) Dimensionless Unit Hydrograph – The hydrograph is computed using basin area, land cover, lag, and precipitation as modifiers to a dimensionless unit hydrograph.
- (3). Combining Hydrographs – In larger Design Drainage Areas covering large Basins or entire Watersheds it may be necessary to combine hydrographs in order to accurately depict the runoff with one hydrograph where two or more sub-areas intersect and combine flows. If this occurs, the drainage report shall explain the location of these intersections, and provide the necessary input files in conjunction with the report.

**b. Assumptions and Limitations**

- (1). Tabular Method of NRCS (SCS) Technical Release No.55
  - a). This method shall be applied according to the instructions and limitations outlined in NRCS (SCS) Technical Release No. 55, and revisions issued by the Natural Resource Conservation Service.
  - b). This method shall only apply to analysis of the Secondary Drainage System.



- (2). NRCS (SCS) Dimensionless Unit Hydrograph Method
  - a). This method is used in the hydrologic analysis for the adopted Flood Studies of the Cities.
  - b). The method shall be used to compute hydrographs at locations in the primary system where the adopted Flood Study does not determine a hydrograph.
  - c). The method shall be applied using the Generalized Computer Program, HEC-HMS, Flood Hydrograph Package developed by the Hydrologic Engineering Center of the U.S. Army Corps of Engineers. At the discretion of the City Engineer the HEC-1 Program may be used.
  - d). Data from the adopted Flood Study shall be used with only the modifications necessary to account for the desired location of the hydrograph. This will typically involve deletion of data for areas outside of (or downstream of) the study location, and modification of the most downstream drainage area and/or routing reach.

**c. Computer Analysis and Simulation**

- (1). A comprehensive hydrologic model of several of the Primary Systems has been adopted by the Cities. Most of the models are applied using Generalized Computer Program, HEC-1, Flood Hydrograph Package of the U.S. Army Corps of Engineers.
- (2). The model uses the following methods available in HEC-HMS:
  - a). Precipitation is computed using the 24 hour rainfall depths (see Table C-6 in Appendix C) distributed according to the Natural Resource Conservation Service Type III Distribution.
  - b). Basin Hydrographs are computed using the NRSC (SCS) Dimensionless Unit Hydrograph Method.
  - c). Routing of hydrographs is computed by Normal Depth Storage and Outflow ("Channel Routing").
- (3). Amendment of the adopted FEMA flood study will be processed by the City as conditions in the drainage basins change based on revised flood study data submitted to the City for review.

*Range of Analyses*

The model consists of analyses of the 10-year, 25-year, 50-year, and 100-year storms for two Design Drainage Area conditions: "Existing" and "Ultimate". The "Existing" condition analysis reflects the land uses and channel conditions in the Design Drainage Area as they exist at the time of analysis. The "Ultimate" condition analysis reflects the fully developed conditions defined by the adopted Comprehensive Land Use Plan guiding development within the City, coupled with the existing channel and floodplain conditions at the time of the study. No allowance is to be made for proposed channelization in determining the "Ultimate" condition flood discharges or elevations.

**C. Applications****1. The Rational Method***Limited Use*

The Rational Formula shall be limited to use in determining the peak discharge from small areas of overland or sheet flow, and concentrated flows in street gutters, storm sewer, and man-made channels. It shall not be used for determining peak discharge from any Design Drainage Area exceeding 50 acres in size nor for determining or estimating storage or discharge requirements for design of detention facilities. Likewise it shall not be used to estimate stormwater discharges of the primary system. Its use is strictly limited to small Design Drainage Areas discharging to the secondary drainage system.

**2. Natural Resource Conservation Service (NRCS) Methods***Primary Use*

Methods promulgated by the NRCS (formerly the Soil Conservation Service – SCS) have a variety of applications. Those detailed in Technical Release No. 55 are for use in determining stormwater discharges and hydrographs in the Secondary Drainage System only and for Design Drainage Areas not exceeding 2000 acres. For purposes of these Guidelines these methods are applicable to Design Drainage Areas of 50 to 2000 acres. In the event a Design Drainage Area exceeding 2000 acres is to be analyzed, the methodology must receive specific approval of the City engineer.

**3. Dimensionless Unit Hydrograph Method**

This method must be used where analysis and design of the primary drainage system is involved.

**4. Detention Facilities**

Storm flow hydrographs for use in designing detention facilities shall be determined using one of the methodologies defined in Paragraph B3 of this Section. The applications and limitations therein stated shall apply.

**Section VI**  
**Hydraulic Design**

**Unified  
Stormwater  
Design Guidelines**

**City of College Station  
City of Bryan**

**August 2012**

### **A. Street Drainage**

#### **1. Design Principles**

*Street Purposes*            The primary purpose of streets is transportation: to offer effective mobility for all users, and to ensure that each land parcel has reasonable access. Stormwater collection and conveyance is an important, but secondary purpose. Consequently, designs for handling storm flow should minimize interference with transportation uses. In general, the more important the street (in terms of functional classification) the more important it is that stormwater design not interfere with transportation uses. Conversely, moderate interference with transportation uses is more acceptable on lower class streets.

*Flow Parameters*            The design flow of water in streets shall be related to the extent and frequency of interference with traffic as related to street functional class and the chance of flood damage to surrounding properties. Interference with traffic is regulated by design limits of the spread of water into traffic lanes. Flooding of surrounding properties is regulated by limiting the depth of flow at the curb and by containment of the 100-year design storm flow within the street right of way.

#### **2. Performance Standards and Limitations**

##### **a. Velocity of Flow**

- (1). The maximum velocity of street flow shall not exceed 10 feet/second. At "T" street intersections flow velocity must be checked on the stem of the "T" to ensure that flow will not traverse the crown and opposing curb of the crossing street and enter onto private property.
- (2). A minimum velocity shall be maintained to ensure cleansing flushes at low flows by keeping the minimum gutter slope to six tenths of one percent (0.006 ft/ft).

##### **b. Allowable Depth of Flow**

*Top of Curb*                    The depth of flow shall be limited to the top of curb for a design storm having a return period of ten years.

*Within ROW*                    Design flows for storms with an average return period up to and including 100 years shall be confined within the limits of the street right-of-way until discharged into a drainage easement or drainage ROW that is part of the designated Conveyance Pathway system, or directly into a main channel of the primary drainage system. The capacity of the storm drain system shall be increased beyond other design criteria in these Guidelines as necessary to ensure this objective. Design computations shall demonstrate satisfaction of this criterion.

**c. Grades and Cross-slopes**

Street grades and cross-slopes shall be consistent with B-CS Technical Specifications.

**d. Allowable Water Spread**

- (1). Local Streets – The design storm flow in local streets shall be limited to the top of crown or the top of curb, whichever is less. Stormwater shall be removed from the streets by inlets or openings into adjacent drainage systems. These shall be placed at low points and as frequently as necessary to avoid exceeding water spread and depth criteria. The design storm shall have a return period of ten years.
- (2). Collector Streets – Design storm flow in collector streets shall be limited so that one 12-foot wide area (one traffic lane width) at the center of the street will remain clear of water. Stormwater shall be removed from the street by inlets or openings into adjacent drainage systems. These shall be placed at low points and as frequently as necessary to avoid exceeding water spread and depth criteria. The design storm shall have a return period of ten years.
- (3). Arterial and Parkway Streets – Design storm flow in arterial and parkway streets (any street having a raised median regardless of classification) shall be limited so that one (1) twelve-foot traffic lane each direction at the center of the street (or one on each side of a raised median) will remain clear of water. Stormwater shall be removed from the street by inlets or openings into adjacent drainage systems. These shall be placed at low points and as frequently as necessary to avoid exceeding water spread and depth criteria. The design storm shall have a return period of twenty-five years.
- (4). Intersections – Inlet placement and storm sewer size shall ensure that design storm flows are intercepted (“dried up”) along street legs entering the intersection in advance of the curb returns connecting the streets based on the criteria provided below. In no case shall inlets be placed in the curved portion of curbs connecting intersecting streets. Where storm flow is allowed to pass through an intersection, valley gutter design must provide for smooth, uninterrupted traffic flow as stipulated by B-CS Technical Specifications.

<u>Intersection Pair</u>	<u>Intercept</u>	<u>Valley Gutter Criteria</u>
Arterial – Arterial	All legs	No valley gutters
Arterial – Collector	All legs	No valley gutters
Arterial – Local	All legs	No valley gutters
Collector – Collector	All legs	No valley gutters
Collector – Local	Local legs	Valley gutters can parallel Collector
Local – Local	Two legs preferred	Valley gutters acceptable

- (5). Mid block Cross Drainage – Where storm drainage is collected on one side of a street and must be conveyed to the other side, it shall be accomplished via underground conduit unless the roadway is functionally classified as a local street. Where storm flow is to cross such a local street the preferred conveyance is via underground conduit, however, at the discretion of the City Engineer, very low design flow may be conveyed in a valley gutter that satisfies B-CS Technical specifications.

### **3. Design Procedure**

#### **a. Straight Crowns**

Flows in streets which have a straight crown will be calculated using the following equation for triangular channels:

$$Q = 0.56 \frac{Z}{n} S^{0.5} Y^{2.67}$$

where,

**Q** = gutter discharge (cubic feet per second)

**z** = reciprocal of the crown slope (ft/ft)

**S** = street or gutter slope (ft/ft)

**n** = Manning's roughness coefficient

**Y** = depth of flow (ft)

When flows over concrete or asphalt pavement are being calculated, the value of "n" shall be taken as 0.018.

#### **b. Parabolic Crowns**

Flows in streets which have a parabolic crown become complicated and difficult to precisely solve for each design case. Design equations must be used to determine gutter flow when street design is to include parabolic crown sections. If parabolic crowns are planned, the concept is to be discussed during the Stormwater Planning Conference with the City Engineer or her/his designee.

## **B. Storm Drain Inlets**

### **1. Principles**

The purpose of a storm drain inlet is to intercept street or surface runoff and direct it into another component of the drainage system, usually an underground conduit. Inlets are typically of the curb opening type for streets and grate type for area drainage. Curb inlets

occur at low points or on grade, and can have a throat that is either depressed or flush with the gutter invert grade. Grate inlets can only occur in low points and may or may not be depressed.

### 2. Street Inlet Criteria

<i>Recessed Inlets</i>	<p>Inlets along arterial or major collector streets shall be recessed (horizontally displaced) away from the line of the curb so that any depression at the mouth of the inlet occurs wholly within the limits of the gutter, with no irregularity of elevation extending into the travel lane. A diagram of a recessed inlet is illustrated in Figure C-1, Appendix C.</p> <p>Inlets on minor collector streets shall be recessed away from the line of the curb when a depression of four (4) inches or greater is used at the mouth of the inlet.</p>
<i>Optional Design</i>	<p>Inlets along streets classified as "local" may or may not be recessed.</p>
<i>Inlet Length</i>	<p>Curb opening inlets shall have a minimum length of five (5) feet, and construction details shall conform to the B-CS Technical Specifications.</p>

### 3. Types of Inlets

<i>Standard Inlets</i>	<p>Standard inlets are classified into two groups: inlets in sumps (Type A) and inlets on grade (Type B). These are further subdivided as follows:</p> <p>Inlets in Sumps</p> <ul style="list-style-type: none"><li>• Curb openings (with or without gutter depression) Type A-1</li><li>• Grate inlet; Type A -2</li></ul> <p>Inlets on Grade</p> <ul style="list-style-type: none"><li>• Curb openings with gutter depression Type B-1</li><li>• Curb openings without gutter depression Type B-2</li></ul>
<i>Combination Inlets</i>	<p>A combination inlet is a side-by-side placement of a standard curb inlet and a grate inlet. The upstream inlet may be a standard curb inlet or simply part of an inlet. The benefit is that the curb opening tends to intercept debris that might otherwise clog the grate inlet. Such arrangements typically offer very little additional capacity over standard depressed inlets. In order to determine the capacity of a combination inlet on grade, it is recommended that the capacity of each (standard and grate) be calculated and the greater capacity be assumed for the pair for design purposes.</p>

### 4. Inlet Location

<i>Limit Conflicts</i>	<p>Inlet locations shall conform to the requirements of paragraph A of this section of these Guidelines, and shall be located as feasible to limit</p>
------------------------	--

conflicts (caused by the inlet itself or associated stormwater) with vehicle, bicycle, or pedestrian traffic.

*Limit Cross-Flow* Inlets shall be located along streets to prevent concentrated stormwater flow from crossing traffic lanes, except as outlined in paragraph A of this section. Typical locations for these conditions are at transitions to super elevated sections, at the ends of long traffic islands, or at the ends of medians in super elevated sections.

*Meet Standards* Specific configuration and exact location of inlets shall be consistent with requirements of the B-CS Technical Specifications but shall not be in conflict with provisions of Paragraph A2-d of this Section.

## 5. Inlet Sizing

### a. Inlets in Sumps

*Minimize Ponding* These inlets are placed at low points to relieve ponding of surface water. For purposes of design, inlets having a gutter depression greater than five (5) inches on streets with less than a one percent (1%) grade may be considered as inlets in sumps.

*Maximum Depth* Under no circumstances shall inlets at low points in streets allow water to pond to a depth exceeding 24 inches above the gutter flow line for up to 100-year frequency design storms based on project buildout and ultimate development conditions. Where computations show that this would be exceeded, provision must be made for an overflow outlet designed to handle the excess flows. This can take the form of a flume draining the street or a swale in an adjacent drainage easement, provided neither present an obstruction to non-motorized travel. Alternatively, the inlet system and receiving facilities shall be oversized as necessary.

(1). Curb Openings Inlets (Type A-1) that are not submerged are considered to function as a rectangular weir with a discharge coefficient of **3.0**. The capacity of a curb opening inlet is found by the following equation:

$$Q = 3.0Ly^{1.5}$$

where:

**Q** = capacity in cubic feet per second (cfs)

**L** = length of the opening which water enters into the inlet

**y** = total depth of water or head on the inlet

*Clogging Factor* Because of the tendency for curb opening inlets in sumps to collect debris, their calculated capacity shall be reduced by ten percent (10%) to compensate for potential clogging.



- (2). Grate Inlets (Type A-2) are considered to function as an orifice with a discharge coefficient of 0.60. The capacity of a grate inlet is based on the following equation:

$$Q = 4.82A_g y^{0.5}$$

where:

**Q** = capacity in cubic feet per second

**A<sub>g</sub>** = clear opening area in square feet

**y** = total depth of water or head on the inlet in feet.

*Clogging Factor*

Because of the tendency for grate inlets to collect debris, their calculated capacity shall be reduced by twenty-five percent (25%) to compensate for potential clogging, except where used as a controlling device in a detention facility.

#### **b. Inlets on Grade**

- (1). Curb Inlets (without gutter depression) Type B-1

The capacity of such inlets is based on the weir equation, reduced to account for street grade and cross-flow effects. The head, “**y**”, shall be taken as the depth of flow at the upstream end of the opening determined via criteria stipulated in Paragraphs A2 and A3 of this Section. Equation 1 in Table C-8 (Appendix C) shall be used to determine the capacities of these inlets on grade, with the value for “**a**” set equal to zero.

- (2). Curb Opening Inlets (with gutter depression) Type B-2

The same guidelines and criteria apply as for those inlets without a gutter depression, except the value “**a**” shall be taken as the gutter depression. The gutter depression is defined as the difference in elevation from the normal gutter grade line to the pavement grade at the throat or entry of the inlet (see Figure C-2 in Appendix C).

- (3). The equations in Table C-8 in Appendix C are to be used to determine the necessary size of curb inlets on grade. The applicable determinates and variables are defined in the table and the purpose of each equation is described.

### **C. Storm Drainage Systems**

#### **1. Principles**

*Conduit System*

Storm Drain systems are conduits for the collection and conveyance of surface water to desired points of discharge. Design is accomplished by application of the Manning equation either directly, or through charts and nomographs derived from the equation. The following general conditions apply to the design.

<i>Accept Design Flow</i>	The system must be designed to accommodate all intercepted flow for the design storm at each inlet and opening that allows stormwater into the system. Preferably the system shall operate “flowing full” and within the theoretical limits of open channel flow for the required design flows.
<i>Future Runoff</i>	Design and construction shall take into account any stormflow from future subdivision areas contributing to the system. No existing system shall have flows added (or directed to it) that will exceed its theoretical design capacity.
<i>100-Year Runoff</i>	The system shall be evaluated with associated drainage systems for the flow conditions that will result from a 100-year frequency rainfall event under ultimate development conditions over the Design Drainage Area. Design shall be revised as required to prevent formation of any conditions that could be considered hazardous to life, property, or public infrastructure, or that could create conditions inconsistent with the requirements of other sections of these Guidelines.

## 2. Initial Design Considerations

### a. Minimum and Maximum Velocities

Minimum velocities are necessary to prevent excessive deposits of sediment that could lead to clogging. The minimum design velocity for conduits flowing full shall be 2.5 feet per second.

Maximum velocities are necessary to prevent excessive erosion of the inverts. The maximum design velocity for conduits flowing full shall be 15 feet per second.

### b. Roughness Coefficients, “n”

Selection of a roughness coefficient should reflect the average condition present during the life of the conduit. Factors to consider are erosion of the interior surface, displacement of joints, and introduction of foreign material and deposits. The following values shall be used for the materials listed:

Reinforced Concrete: 0.013

Ductile Iron or steel (Smooth): 0.010

Corrugated Metal: 0.024

Smooth lined High Density Poly-Ethylene (HDPE): 0.012

Non-lined High Density Poly-Ethylene (HDPE): 0.020

### c. Location of Manholes and Junction Boxes

- (1). Junction boxes shall be provided at all changes in conduit size and grade, and where changes in alignment are made at pipe joints

Manhole access shall be provided as part of the design of all junction boxes unless otherwise approved by the City Engineer.

- (2). Manholes shall be provided at intervals not to exceed 300 feet for conduits 54 inches in diameter or smaller. For conduits exceeding 54 inches in diameter, the interval between openings shall not exceed 500 feet.

**d. Minimum and Maximum Grades**

- (1). The minimum grade for conduits shall be that necessary to produce the minimum acceptable velocity per Paragraph C2-a.
- (2). In order to prevent formation of a hydraulic jump conditions at the terminus of a conduit, the maximum grade along the outfall shall be less than the calculated grade that would result in supercritical flow, except where approved energy dissipation measures are used.

**e. Minimum Pipe Diameter**

*18-Inch Usual*

In most instances conduit that will become an integral part of the public storm sewer system shall have a diameter of 18 inches or greater. For design purposes, conduits having a diameter of 24 inches or less shall be assumed to have a twenty-five percent (25%) reduction of cross-sectional area to compensate for potential partial blockage.

*Limited 12-Inch*

At the discretion of the City Engineer, short laterals connecting inlets to a main line, and the last run of conduit at the uppermost end of a main line, may be twelve (12) inches in diameter. In no case shall a run of twelve-inch conduit serve more than one inlet or exceed a length of 30 feet.

**f. Other Considerations**

- (1). Designs shall attempt to increase the velocity in the downstream direction.
- (2). Pipe sizes shall increase in the downstream direction, regardless of additional capacity developed by increased grade, and pipe soffit (inside top) elevations shall be aligned.
- (3). An elevation drop is to be provided at all inlets, manholes, and junction boxes equal to the change in pipe diameter or a minimum of one tenth of a foot.
- (4). Pipe shall be placed on the design friction slope as much as practical.

### 3. Hydraulic Design Requirements

**a. Flow Assumptions and Manning's Equations**

Design shall be by application of the Continuity equation and Manning's Equation as follows:

$$Q = AV$$

$$Q = \frac{1.49}{n} AR^{0.67} S_f^{0.5}$$

where :

**Q** = flow in cubic feet per second

**A** = cross sectional area in square feet

**V** = velocity of flow in feet/sec

**n** = roughness coefficient of conduit

**R** = hydraulic radius = **A/WP** in feet.

**WP** = wetted perimeter in feet **S<sub>f</sub>** = friction slope of conduit in feet/foot

Capacity of a given size conduit is based on an assumption that it is "flowing full". Thus, **R** is equivalent to the cross sectional area divided by the inner circumference, while a value for **n** and **S<sub>f</sub>** must be chosen.

#### b. Head Losses and Friction Losses

Head losses computed at junctions, inlets, and manholes shall be determined using the following equation:

$$h_j = k_j \left( \frac{V_2^2 - V_1^2}{2g} \right)$$

where:

**h<sub>j</sub>** = head loss in feet at structures

**V<sub>1</sub>** = velocity at upstream entrance of structure (feet per second)

**V<sub>2</sub>** = velocity at downstream exit of structure (feet per second)

**k<sub>j</sub>** = structure coefficient of loss (Table C-9, Appendix C)

**g** = 32.2 feet per second per second

Head losses due to friction for open channel flow conditions are found by the following equation:

$$h_f = S_f L$$

where:

**h<sub>f</sub>** = head loss due to friction in feet

$S_f$  = friction slope (normally equal to the slope of the conduit,  $S_o$ ),  
in feet per foot

$L$  = length of conduit in feet

**c. Computation of Hydraulic Grade Line**

All designs shall verify the elevation of the hydraulic grade line by calculation along the length of the system for two conditions. For the 10 year design storm the theoretical hydraulic grade line shall be verified as being at least one half foot (0.5 feet) below the inlet opening elevation, the gutter elevation, or the ground surface which ever is lowest. The hydraulic grade line shall also be calculated for the 100-year frequency storm assuming ultimate development conditions in the Design Drainage Area, and must be kept within the limits specified in all other sections of these Guidelines.

**d. Allowance for Surcharging**

Design of the system and evaluation of hydraulic grade lines shall take into account the tail water elevation at the outlet or final discharge point. Discharge at free outfalls shall assume a starting water surface elevation at the soffit of the conduit. For outlets that might operate in a submerged or partially submerged condition, the starting water surface elevation shall be taken as the water surface elevation of the receiving facility at that location or the conduit soffit, whichever is highest.

**4. Use of WINSTORM Program**

Use of the WinStorm computer program is acceptable for calculating the capacity of inlets and storm drain systems. The program is available at no cost through TxDOT's web site. If WinStorm is used as a design aid for a project, the complete report the program can generate shall be submitted as part of the drainage report. In addition, both an analysis layout and an electronic medium (diskette or CD) of the analysis shall be provided.

**D. Open Channels**

**1. Principles**

Analysis of open channels is necessary to determine the depth and velocity of a given flow for an established cross-section. Typical uses are to determine the tail water and/or the back water condition(s) at a culvert structure, flood elevation for selected discharge of natural streams and watercourses, and discharge capacities for existing or proposed designed channels.

*Design Objectives* Design of open channels involves the selection of a cross-section, surface treatment, and alignment to accommodate some series of design discharges. A successful channel design can take one of two basic forms. It can replicate the features and characteristics commonly found in natural streams, or it can provide the characteristics of traditional constructed channels. In either case the design objective is to provide stable structural components that will not develop excessive sediment deposits or erosive cuts, that will maintain a stable cross-section, that will minimize the need for maintenance, and that will not be damaged by entry of uncontrolled surface flows.

*Natural Designs* Leaving streams in their natural state offers numerous advantages, so this practice is preferred. Designs that replicate the characteristics of natural streams are encouraged, provided they meet the objectives of the provisions in these Guidelines. Such a design approach may be required at the discretion of the City Engineer. Where plant growth and hydro-environments can be created or maintained to accomplish stabilized channels they are encouraged. Such designs must ensure that long term maintenance costs are not likely to be greater than would be expected from the use of traditional channel lining treatments.

## 2. Determination of Water Surface Profiles

### a. Methods of Analysis

#### (1). Manning's Equation

The equation is expressed as follows:

$$Q = \frac{1.49}{n} AR^{0.67} S^{0.5}$$

where:

**Q** = the discharge in cubic feet per second

**n** = Manning's Roughness Coefficient

**A** = cross-sectional area representing the depth of flow in feet

**R** = hydraulic radius = **A/WP** in feet.

**WP** = wetted perimeter of channel section for area "**A**" in feet

**S** = slope of channel bed in feet/foot

The equation is applied to a single cross-section and assumes a uniform channel cross-section and slope as well as steady, uniform flow in the channel. Consequently, its use shall be limited to designed channels and suitable natural channels in the secondary drainage system.

(2). Standard – Step Procedure

This procedure shall be used in analyzing natural or man-made channels of the primary drainage system. It may also be applied to open channels in the secondary drainage system.

*Bernoulli's Equation*

The procedure involves application of Bernoulli's Equation to a series of stream cross-sections using the continuity equation, the velocity head, and Manning's Equation as inputs. A detailed description is beyond the scope of these Guidelines.

*HEC-RAS Software*

The method shall be applied using the HEC-RAS software endorsed by the Hydraulic Engineering Center of the U.S. Army Corps of Engineers, or other computer analysis programs employing the same methodology. The application shall be according to the recommendations contained in the user's manual for the program.

**b. Primary Design Parameters**

(1). Channel Section

Cross-section(s) should be representative of the channel reach being studied.

(2). Manning's Roughness Coefficients ("n" values)

Section of values for "n" shall fall within the range of values and descriptions given in Table C-10 in Appendix C.

(3). Channel Slope

The slope of the channel shall be taken as the average slope along the reach being studied.

**c. Determination of Flow Character**

In order to prevent formation of areas of supercritical flow and hydraulic jumps except where planned, flow must be kept within the limits of sub-critical flow. To do this, design flow depth must be greater than critical depth. For non-rectangular channels, the critical depth can be found through application of trial depths and the following relationship:

$$\frac{Q^2}{g} = \frac{A_c^3}{T_c}$$

where:

**Q** = discharge in cubic feet per second

**g** = 32.2 feet per second per second

**A<sub>c</sub>** = cross-sectional area of flow at critical depth in square feet

**T<sub>c</sub>** = top width of critical flow in feet.

For non-uniform cross sections, a rating curve of critical depth versus discharge shall be constructed.

Once the discharge **Q**, area **A**, and depth **d** are determined, the slope necessary to produce these conditions in a channel can be computed from Manning's Equation.

### **3. Design of Open Channels**

#### *Traditional Designs*

The criteria outlined in this section are intended to guide the development of traditional designed/constructed open channels. Roadside ditches shall be designed as open channels per the Guidelines in Paragraph D4 of this Section. Alternate channel designs will be considered by the City Engineer provided they are shown to meet the intent of these Guidelines.

#### *Natural Designs Encouraged*

Designs intended to replicate the characteristics of natural streams are encouraged but must be shown to satisfy the essential purposes of the provisions of this paragraph. Example features that might be considered for such designs are among those outlined in Appendix E.

#### **a. Physical Considerations**

##### (1). Cross-Section Geometry

The minimum standards acceptable for use in traditional lined channel design are in the B-CS Technical Design Specifications. The maximum side slope shall be four horizontal to one vertical (4:1).

##### (2). Minimum and Maximum Grades

The minimum longitudinal slope shall be 0.006 foot per foot (0.6 percent) for earthen or vegetative lined channels to prevent formation of standing water. The maximum allowable grade shall be a function of allowable flow velocity as related to channel lining materials stipulated in Table C-11 (Appendix C). If the proposed maximum grade will exceed 70 percent of the calculated critical slope values for the required range of design flows, special channel linings and energy dissipation features must be used to compensate for the high velocities and hydraulic jumps associated with supercritical flow. Designs for supercritical flow are limited to straight sections having a minimum grade that is at least 130 percent of the critical slope values calculated for the required range of design flows.

##### (3). Bends and Horizontal Curves

The maximum allowable deflection angle for bends in designed channels shall be 45 degrees. The outside of horizontal curves shall provide additional channel bank height and surface treatment as necessary to fully contain the design flow and prevent erosion and overtopping.





### c. Outfall Junctionures

*Juncture Important* Where part of a storm drainage system discharges into another part of the system, on-going long-term maintenance difficulties can result, particularly where the receiving facility is an open channel. The complexity and importance of these junctures warrants careful design attention.

*Juncture Categories* Junctures can be grouped into three categories: discharge from an under ground storm sewer conduit into the secondary or primary drainage system; discharge of an open flume into the secondary or primary drainage system; and the confluence of two channels (secondary/secondary or secondary/primary).

*Public System* The following guidelines apply to points of discharge into the public stormwater conveyance system, whether from a private or public drainage facility.

#### (1). Storm Sewer Outfall Points

*Acute Connections* Where storm sewer lines are to discharge directly into culverts or channels they must do so at an acute angle (preferably not exceeding 45 degrees) so that flow is generally in the same direction as the flow of the receiving facility. Where discharge is into a culvert, the connection should match the soffit elevation of the two facilities as closely as practical. Connection details and grouting shall be in conformance with the B-CS Technical Specifications.

*Match Inverts* Where discharge is directly into a designed or natural watercourse, the discharge invert elevation should match that of the receiving facility as closely as practical. Alternatively, special channel treatment designs may be proposed so that the outfall discharge will not inhibit or obstruct flow in the receiving channel. In either case, the design must work to manage the velocity of the outfall discharge to prevent scour of the bottom or sides of the receiving channel.

#### (2). Flume Outfall Points

*No Erosion, Scour* Flumes that convey stormflow into a natural or designed watercourse shall be designed to prevent storm flow from interfering with the integrity of the bottom or sides of the receiving facility. This will necessarily involve managing discharge velocity to avoid scour, as well as possible treatment of portions of the receiving water course. No such connection shall inhibit or obstruct conveyance of the design storm flow of the receiving water course.

#### (3). Points of Channel Confluence

*Control Turbulence* Channel confluences should be at 45 degrees or less, and the design should bring flows together as nearly as possible at the same velocity in order to minimize turbulence. The design must include treatments to ensure adequate erosion control consistent with provisions in Section VII of these Guidelines.

**4. Roadside Ditches**

Where the use of roadside ditches is approved by the City Engineer, the design shall be governed by provisions for open channel flow as set out in the forgoing paragraphs of this Section, unless superseded by higher or more explicit standards as outlined below.

**a. Hydraulic Design of Ditches**

- (1). Ditches must completely contain the flow from the design 25-year storm with a water surface elevation six (6) inches below the top of the ditch.
- (2). The maximum 25 year design depth of flow shall be limited to three (3) feet.

**b. Ditch Geometry**

- (1). Culverts must be at least 18 inches in diameter.
- (2). The top of the ditch bank must be separated laterally from the roadway shoulder (edge of base course) by at least two (2) feet.
- (3). Ditch sections shall have a minimum depth of one and one half (1.5) feet.
- (4). Side slopes shall be no steeper than four horizontally to one vertical (4:1).

**c. Ditch Construction**

- (1). Culverts and grading shall be constructed in compliance with B-CS Technical Specifications.
- (2). All ditches must be completely vegetated in accordance with B-CS Technical Specifications.
- (3). All computations and design drawings shall demonstrate satisfaction of design provisions of these Guidelines.

**5. Modification of Natural Watercourses****a. FEMA and “Non-FEMA” Systems**

Both the Primary and Secondary Systems include natural watercourses of various sizes and capacities. The great majority of these watercourses form the FEMA-designated Floodplains as defined in paragraph G of this Section. Most of the remaining natural watercourses are generally upstream extensions of those forming the FEMA-designated system. For purposes of these Guidelines natural watercourses shall be considered to be in one of two categories: as part of the Named Regulatory Watercourses defined in Section II (the “FEMA-Designated Flood Plain System”), or as “Non-FEMA” watercourses.

### b. FEMA-Designated Flood Plain System

Watercourses making up the FEMA-Designated Flood Plain System must be in compliance with the requirements of paragraph G of this section, in addition to provisions of this paragraph (D-5) and its subparagraphs.

### c. Principles

- (1). Modifications shall be defined as physical changes in a watercourse's vertical and/or horizontal alignment, cross-section geometry, surface characteristics, or over-bank areas. Movement or addition of earthen materials, grubbing, and wholesale removal of vegetation is considered modification activity, but trimming of vegetation is considered maintenance and is not governed by these Guidelines.
- (2). At a minimum, all modifications to natural watercourses shall meet the requirements governing design or improvement of open channels stipulated elsewhere in these Guidelines.
- (3). Changes to natural watercourses must be consistent with an approved master plan for modification of a complete reach of the Primary System if such a master plan exists. If no plan exists, one may be required at the discretion of the City Engineer. Changes to short parts of a natural watercourse must demonstrate compatibility with similar modifications along the length of that reach, whether existing or planned.
- (4). On any site that is a single platted lot, minor encroachments, consisting of fill and earthwork changes in existing defined floodway fringe areas may be allowed at the discretion of the City Engineer. Any encroachments shall meet all requirements listed in the following sub-paragraphs.

### d. Determination of Floodway and Floodplain Areas

- (1). For streams forming the primary drainage system, a comprehensive hydraulic model, referred to as the City's Flood Study, has been adopted. This study shall be used as the principal source defining floodway and floodplain areas for streams and channels making up the primary system.
- (2). Along streams and channels lacking an existing study, floodway and floodplain areas shall be determined by extending the adopted Flood Study using the standard step procedure. Where new flood discharges must be determined, they shall be computed using the methods outlined in Section V of these Guidelines.
- (3). Land development projects proposing to use land filling or berms or structural features to raise existing floodplain areas above flood levels are considered encroachments into floodplain areas. Because this will raise the base flood elevations (BFE) in the vicinity of the proposed work the extent of encroachment must be limited so that the BFE is not raised by more than one foot. These geographic limits will define the

resulting “floodway” for that Watercourse, or tributary thereof. This effect is illustrated in Figure C-3, Appendix C.

- (4). The floodway shall be determined using an encroachment method based on proportionate conveyance reduction (as a function of hydraulic cross sectional areas) from both sides of the channel over-bank. However, the limits of encroachment shall not extend into the designated channel area. The engineering studies necessary to identify “floodways” rests with the owner/developer (or the applicant) of the proposed project at the discretion of the City Engineer or his/her designee.

**e. Design Considerations**

- (1). Analysis for System Impacts

*Modified Channels*

When existing channels are straightened, improved in cross-section, and/or lined, their hydraulic efficiency increases. Such action results in reduced travel times and reduced times of concentration. It can also result in loss of over bank storage capacity. These factors cause higher flood discharges and higher flood elevations downstream of the area of improvement. Any changes to channels within the Primary System shall be accompanied by a revised analysis of the hydrologic model (both current condition and ultimate condition) of the adopted Flood Study. The changes will be reflected in the routing reaches and lag factors for affected channel reaches and s.

*Downstream Effects*

Downstream impacts shall be reviewed to prevent damage to existing property and structures. Key items shall include the effect of higher discharges at bridges and culverts, and the changes in flood elevations. Channel improvements shall not cause increases in flood discharges that will exceed the capacity of downstream crossing structures, and shall not raise ultimate 100-year flood elevations.

- (2). Transition Sections

*Smooth Transitions*

Modification of any channel section shall include designs to affect smooth transitions with the existing channel features, both upstream and downstream. These transitions should be gradual to prevent the formation of excessive energy losses and turbulence, or the creation of inappropriate velocities in upstream or downstream sections of the channel. Any proposals for abrupt changes in section, profile, or alignment must be accompanied by engineering studies demonstrating that planned energy dissipation measures will preserve the long term integrity of channel elements. Energy dissipation measures must be acceptable to the City Engineer.

### E. Detention Facilities

#### 1. Principles

- Controlled Discharge* The purpose of a detention facility is to store excess stormwater runoff and discharge it at a predetermined controlled rate. Typically, this is done so that discharge rates from a development site will be limited to those that existed prior to any land development activities. This is accomplished for a range of design storms.
- Facility Types* As a function of how they are designed to operate, detention facilities can be grouped into three categories. One type is effectively a permanent pond. That is, it retains a significant water pool on a year-round basis, but acts to detain stormflow, metering water release until some predetermined pool level is reached. This might be termed a “pool-type” (retention) facility. Another type might be termed a “wetland-type” facility. This type retains storm flow and meters its release, but is not intended to drain fully dry. Rather, an aquatic ecosystem is specifically designed into part or all of the facility so that it is sustained by the storm flow that passes through the facility. The third type is designed to drain fully dry between storm events, a “dry-type” facility.
- Detention Philosophy* These Guidelines are largely oriented toward development of “dry-type” facilities. However, where topographic, water, and other physical characteristics make it feasible to design viable “wetland-type” facilities, they are encouraged. Successful “wetland-type” or “pool-type” facilities can be difficult to establish and are highly dependent on an expert multi-discipline design team for their success. Use of a “wetland-type” or “pool-type” facility will be considered a special design, and must be approved by the City Engineer on a case-by-case basis. The City Engineer must be informed early during the planning of a project. In addition, the design must be handled by qualified professionals, experienced in establishing self-sustaining wetland environments. The stormwater detention function shall not be compromised by such special designs.
- Drained Areas* Detention facilities may be site-specific, or may be designed for a specific land development project comprised of multiple lots, streets, utilities, and other infrastructure elements. In any case, their primary purpose is to protect immediate downstream properties and drainage system from excessive stormflow. One detention facility, or a system of facilities, may be necessary to meet stormwater management objectives for an entire Project Area. A site-specific example would be using a detention facility in a large parking area to avoid overwhelming adjacent streets and storm sewers of the secondary system. Common methods include use of depressions in parking lots and/or landscaped areas that drain dry between rainfall events.

<i>Regional Detention</i>	Detention facilities also may be regional in scope, receiving stormwater from many land development Project Areas and/or sites. In such situations a limiting capacity is often that of the drainage system that traverses an exiting developed area.
<i>Multi-Purpose Areas</i>	A regional facility requires a large land area for the required storage and, thus, is usually designed for multiple uses compatible with its stormwater purpose. For best results, these are permanent storage (“pool-type”) facilities designed to hold water between rainfall events, and may be combined with green-space and recreation areas.
<i>“Regional” Limited</i>	Detention facilities will only be considered “Regional” at the discretion of the City Engineer.

## 2. Design Parameters

### a. Design Storm

*Secondary System* Any detention facilities to be located in the Secondary Drainage System that are site-specific, or will serve a specific development project, shall use a maximum design storm based on specific detention requirements stipulated in these Guidelines. The following sequence of design storms shall be used until the maximum design storm is reached: 2-year, 10-year, 25-year, 50-year, and 100-year. Full consideration must be given to the receiving facilities of the secondary system relative to performance standards and Conveyance Pathway requirements. In addition, the 100-year design storm shall be evaluated to check emergency overflow requirements of the detention facility and the effects of resulting flows on downstream drainage systems.

*Primary System* Where detention facilities are required to be located in the primary drainage system, either on-line (astride the main channel) or as an adjacent flood relief feature, they shall use a maximum design storm having an average return period of 100 years or greater as determined by the City Engineer.

### b. Delineation of Drainage Area

Each detention facility shall serve a Design Drainage Area that contributes (or will contribute) runoff to the facility. The Design Drainage Area and the runoff computations shall be determined for existing pre-development conditions and for expected post-development conditions.

### c. Pre-development and Post-development Hydrographs

A pre-development hydrograph representing the Design Drainage Area and land cover conditions existing prior to the proposed development shall be determined. Likewise, a post-development hydrograph shall be determined representing the Design Drainage Area and land cover

conditions proposed to exist after buildout of the Project Area that contributes runoff to the detention facility.

Hydrographs shall be determined using the appropriate methods from Section V (Hydrology) of these Guidelines.

**d. Determination of Storage Volume**

<i>Pre/Post Flows</i>	Storage volume shall be adequate to ensure that the peak discharges from the detention facility determined via the post-development hydrographs will be limited to values equal to, or less than, the peak discharges determined by the pre-development hydrographs for the design storms.
<i>Existing Storage</i>	Any land features, such as low areas or ponds, having the effect of storing or detaining stormwater during pre-development conditions shall not be ignored in determining the required post-development storage volume. If such features are to be altered or eliminated, then the required storage volume must be increased to account for their pre-development detention characteristics. The existence and effects of such features shall be disclosed during the design review process.
<i>Storage Routing</i>	All detention facilities shall have the necessary storage volume determined from storage routing analysis procedures.

**e. Storage Routing Analysis**

The basis of this method is the continuity equation modified to yield the following:

$$(I_1 + I_2) + \left( \frac{2S_1}{dt} - O_1 \right) = \left( \frac{2S_2}{dt} + O_2 \right)$$

where:

**I** = the inflow over time period t,

**O** = the outflow over time period t,

**S** = the storage volume,

**dt** = the designated time period, and

**subscripts 1** and **2** represent the beginning and end of time period respectively.

The use of this procedure is based the following assumptions:

- The inflow hydrograph is known.
- The starting conditions of storage volume and outflow are known at the beginning of the routing.
- The discharge rate at the outlet structure(s) is only a function of the head available.



- The relationship between depth and storage are known.
- The time period “dt” shall be taken as less than or equal to  $1/5 t_c$  (time of concentration).

### f. Outlet Structures

- (1). Design of outlet structures shall consider the conditions for all required design storms. The structure shall limit the peak discharge to be equal to, or less than, the peak discharge that existed under pre-development conditions for all design storms.
- (2). Except for facilities designed to have a permanent storage component, outlet structures shall be designed to allow the facility to be drained dry by gravity.
- (3). An emergency overflow outlet shall be provided with a capacity to carry the peak discharge from a 100-year frequency storm for buildout conditions over the entire Design Drainage Area. This discharge must be limited and directed in a manner that will: prevent damage to adjacent properties or public infrastructure; avoid damaging the structural integrity of any element of the detention facility; and present no hazardous conditions. In addition, the discharge shall be evaluated for its effect on the downstream receiving drainage system, and shall not exceed its capacity to control and contain the storm discharge assuming ultimate conditions.
- (4). Analysis and design of outlet works shall use the methods promulgated by these Guidelines, namely those dealing with drainage inlets, drainage conduit, open channel flow, and culverts. In addition the B-CS Technical Specifications shall apply.

### 3. Physical Characteristics for Dry-Type Facilities

#### a. Side and Bottom Slopes

- (1). Side slopes shall not exceed 4:1 for vegetative cover and 2:1 for non-vegetative cover.
- (2). Bottom slopes must be a minimum of 5 percent (5%) for a vegetative cover and 0.5% for a flume section or steeper and directed to the low flow outlet.
- (3). A low-flow invert section of concrete or other materials acceptable to the City Engineer shall be provided for all facilities proposed to have a bottom with vegetative cover. To minimize the need for these sections, designs are encouraged to locate the inflow and outflow points as close to each other as practical.

#### b. Emergency Overflow Requirement

- (1). All detention facilities shall be fitted with an emergency overflow feature that discharges into a recognized drainage facility acceptable to the City Engineer.

- (2). The geometry of an emergency overflow structure shall be that of a rectangular or trapezoidal weir.
- (3). The surface treatment of the structure and its discharge path to a recognized drainage facility shall give due regard to maintenance. Velocities shall be limited to be consistent with the proposed surface treatments to prevent erosion, prevent undercutting of structural components, and avoid other maintenance difficulties.
- (4). The elevation of the weir crest shall not be less than the water surface elevation resulting from the design 100-year storm, assuming a fully operating discharge structure. See diagram presented in Figure C-4 in Appendix C.
- (5). The entire perimeter of the facility shall have at least one half (0.5) foot of freeboard above the water surface elevation generated by the 100-year storm assuming buildout conditions of the Design Drainage Area, a completely clogged discharge structure, and a fully functioning spillway.

**c. Storage Depth**

In parking areas the maximum design storage depth, based on site buildout conditions, shall not exceed six (6) inches.

**d. Retention (Permanent Storage) Facilities**

All facilities located astride natural streams or water courses that are designed with a permanent storage component shall meet all design and construction criteria for dams and reservoirs as required by the Texas Commission on Environmental Quality (TCEQ).

**e. Allowance For Sedimentation**

The design storage capacity of detention facilities shall be increased by ten percent (10%) to allow for sedimentation.

## **F. Culverts and Bridges**

### **1. Principles**

*Transportation Purpose* The purpose of a culvert or bridge is to allow a transportation facility to cross a drainage way. Consequently, its primary function is to satisfy transportation purposes. Designs to accomplish this end necessarily involve satisfying both hydrologic and transportation parameters.

*Design Objectives* Hydrologic parameters are established to achieve important design objectives: safety of transportation users; safety of surrounding properties; long term integrity of constructed facilities; minimum maintenance costs; and integrity of the natural environment.

*Parameters Vary* Not all parameters are universally applicable to drainage way crossings. Because transportation facilities (roadways) vary in their function and importance, related hydrologic parameters are varied accordingly. Conversely, parameters relating to the integrity and maintenance of constructed facilities, and those relating to potential flooding of adjacent properties cannot vary.

### 2. General Parameters

*100-Year Discharge* The design storm discharge shall be based on the ultimate development conditions that are projected to exist in the Watershed or served by the watercourse to be crossed. In addition to satisfying parameters for passing the design discharge, the 100-year storm flow must be accommodated. Arterial and major collector roadways are not to be topped by flow from the 100-year design storm. Certain minor roadways may be topped according to criteria set out in Paragraph F3-c below.

*Minimize Erosion and Siltation* Structures shall include design features that can receive the discharge of street or storm drain flow in a manner that will prevent erosion or scour of adjacent embankments or the floor or walls of the channel. Typically, a concrete apron or other suitable surfacing shall be provided to receive the discharge. Multiple barrel culvert crossings shall be designed such that a single barrel has a "lower flow-line" where the proposed 2 year design flow velocity will match or exceed the channel during a 2 year storm event. Similarly, bridge crossings shall have a "low-flow channel" designed to meet the same velocity design. This design intent is to ensure that the smaller, more frequent storms passing through crossings do not lose velocity and energy causing siltation deposits which commonly become performance and maintenance problems.

*Flood Hazard Areas* Structures within established areas of special flood hazard as defined by the flood plain management ordinance(s) of the City shall meet all the requirements for those areas as a minimum. These Guidelines supersede provisions for such areas only to the extent that more stringent requirements are promulgated.

### 3. Design Limitations and Performance Criteria

#### a. Determination of Design Discharges

- (1). For structures over Named Regulatory Watercourses or their direct tributaries, the design discharges shall be determined from the adopted Flood Study of the City per Section II of these Guidelines.
- (2). For structures over watercourses making up the secondary system, the design discharges shall be determined using the appropriate methods outlined in Section V of these Guidelines.

**b. Maximum Operating Headwater**

- (1). For all discharges up to and including the 100-year frequency storm culverts shall be designed to limit upstream headwater to elevations that will not endanger their structural integrity or cause flooding to adjacent structures or properties.
- (2). At bridge crossings the water surface elevation of the 100-year storm flow shall not be higher than one (1.0) foot below the lowest bridge support stringers.
- (3). For culvert crossings the upstream headwater elevation for the design discharge shall be at least one (1.0) foot below the lowest top of curb at the crossing.

**c. Allowable Over-Road Flow***Over Minor Roads*

Where a roadway classified as a local street or minor collector will be topped by flow from a 100-year frequency storm due to allowable lesser design storms for a culvert, the excessive storm flow may be conveyed over the roadway provided the following criteria are met.

- (1). Roadway and storm drainage features must be designed so that all over-road storm flow is conveyed across the road and routed to the downstream watercourse without endangering adjacent properties or structures.
- (2). The maximum depth of over-road flow shall be two (2.0) feet, measured from the roadway crown at the lowest point in the roadway profile.
- (3). Considered together, the velocity and depth of over-road flow provide an indication of the potential detriment to the structural integrity of the roadway. Therefore, the product of the velocity of the overflow discharge (in feet per second) and the maximum depth of flow (in feet) as described in the foregoing paragraph shall be less than six (6), a dimensionless number. The overflow velocity shall be determined from the continuity equation as follows.

$$V = \frac{Q_{\text{over}}}{A}$$

where:

**V** = velocity in the overflow discharge, feet per second.

**Q<sub>over</sub>** = maximum discharge over roadway, cubic feet per second.

**A** = area of the overflow section described by the headwater elevation and roadway profile at the crown.

**d. Maximum Discharge Velocities**

The velocity of discharge through a structure shall be limited based on channel conditions immediately downstream of the structure. Reference is made to Table C-11 in Appendix C. For discharges from the five-year design storm, downstream conditions will be evaluated to the point where normal flow characteristics are re-established in the receiving channel, but not less than a distance that is four (4) times the difference between the width of the downstream flow and the width of the structure opening. This does not apply for discharges from less frequent storms.

**4. Physical Configuration****a. Alignment Criteria**

- Match Flow Lines* Bridges and culverts beneath roadways should provide flow lines that match, as closely as possible, the alignment of the watercourse they are to serve. At the same time, it is desirable for watercourses to cross roadways in a perpendicular manner. Where both of these design objectives can not be reasonably satisfied, the amount of skew in crossing a roadway should be minimized. In addition, the hydraulic demands resulting from introducing any artificial turns in a watercourse must be fully accommodated by the design.
- Driveway Culverts* Where driveways must cross roadside ditches, culverts shall be placed in public right-of-way, generally parallel to the street, and aligned with the flow line of the ditch.
- Straight Structures* Changes in bridge or culvert alignment shall not occur within the right-of-way of the roadways they cross.

**b. Right-of-Way / Easements**

- ROW At Roadways* At roadway crossings right of way must be provided to fully contain all bridge and culvert features, including headwalls, end-walls, wing-walls, and any support structures. This can be in any combination of right-of-way for the roadway and/or the watercourse.
- 100-Year Easements* Where culverts are designed to convey flow less than that generated by the 100-year design storm, areas inundated by backwater conditions shall be wholly contained in right-of-way or drainage easements.
- Pass 100-Year* Bridges are to be designed to pass the flow from the design 100-year storm and, therefore, are not to create a design backwater condition requiring easements or right-of-way. If storm flow exceeding the 100-year design is to be routed around a bridge opening and over the roadway approaches, right-of-way must be provided for the path of the routed flow.

**c. Culvert Ends**

The following guidelines shall be used in designing culvert end treatments. Figure C-5 (Appendix C) shows a schematic diagram illustrating terms commonly used to describe a typical culvert structure.

- (1) Concrete headwalls and end-walls shall be provided to be functionally monolithic with the culvert conduit and must generally be parallel with the alignment of the crossing roadway. Related wing walls shall generally be oriented according to the flow characteristics of the crossing watercourse. In no case shall headwalls or wing walls restrict the clear opening of the structure.
- (2) Flared wing-walls shall be used where both of the following conditions apply:
  - Approach velocities exceed six (6) feet per second for the design discharge
  - The approach channel is irregular and not well defined.
- (3) Wing-walls parallel to the flow line of a watercourse may be used where all of the following conditions are met:
  - Approach velocities are less than six (6) feet per second for the design discharge, and
  - The channel is well defined and regular in cross section, and
  - Downstream channel surface protection is not necessary.
- (4) The maximum side slopes for all grading in the vicinity of culvert headwalls shall be six horizontal to one vertical (6:1), unless 4:1 or flatter is approved via a design exception approved by the City Engineer.

**5. Bridge and Culvert Hydraulic Design****a. Analysis Methodology***Bridge Hydraulics*

The following items shall be addressed as part of the engineering design and analysis of crossing structures. Bridges shall be analyzed for hydraulic conditions using the HEC-RAS Water Surface Profiles computer program applied using the guidelines and recommendations of the U.S. Army Corps of Engineers. Unless other parameters can be substantiated to the satisfaction of the City Engineer, the following nine shall apply:

- A combination of TP40 and Hydro 35 Precipitation Data as provide in Table C-6, Appendix C.
- 10, 25, 50, 100, and 500 year rainfall runs.
- Lag Times for the unit hydrograph should be computed using the NRCS (SCS) lag equation.

- Rational Formula should be used for the peak Q from Design Drainage Area less than 50 acres in size.
- Balanced triangular hydrograph for the PH record in HEC-1 should be used for draining between 50 and 200 acres, and lag times less than 30 minutes.
- NRCS (SCS) Type III, 24-hour duration storm should be used for drainage s larger than 200 acres or lag times exceeding 30 minutes.
- Modified-PULS for Channel Routings and PULS may be used for steep slopes.
- Losses should be computed using the NRCS (SCS) curve number method.
- The NRCS (SCS) unit hydrograph technique is encouraged where no data is available to estimate other parameters.

### *Culvert Hydraulics*

Culverts may be analyzed using the same method as for bridges. Additionally, they may be analyzed using accepted charts and nomographs for the type of structure and material proposed for use. TxDOT's Hydraulic Manual contains a complete treatment of culvert analysis and design, including nomographs. The latest version of TxDOT's Hydraulic Manual shall be considered the standard for analysis of culverts by these Guidelines.

### **b. Culvert Operations**

The rate of flow through a culvert barrel is limited by several direct factors such as slope, length, and surface roughness. Where conditions at the culvert entrance (inlet) prevent optimum flow based solely on these factors, the culvert is considered to operate under "inlet control". When the flow permitted through the barrel is less than the flow allowed at the upstream entrance, the culvert is considered to operate under "outlet control" (sometimes referred to as "barrel control"). For each design discharge the type of control shall be determined.

### **c. Headwater and Tail Water Elevations**

- (1). Tail water elevations shall be determined using one of the methods described in the portion of this Section guiding open channel design (see paragraph D2-a).
- (2). Headwater elevations shall be determined by adding the total head losses through the structure to the tail water elevation, for the given discharge.

### **d. Head Losses**

The total head losses, **H**, on a structure is the sum of all losses due to exit, friction, and entrance conditions for the given discharge.

- (1). Entrance losses are caused by the narrowing of flow from the normal channel width to the structure opening (predominant for bridges), or to the shape or condition of the actual inlet or opening (predominant for culverts). Channel losses of this type must be computed using a standard step procedure as outlined in the part of this Section dealing with open channels. Entry losses shall be computed using the following equation:

$$H_e = k_e \left[ \frac{V_2^2}{2g} - \frac{V_1^2}{2g} \right]$$

where:

$H_e$  = entrance head loss, feet

$V_2$  = velocity of flow in culvert, feet per second

$V_1$  = velocity of flow in approach channel, feet per second

$g$  = 32.2 feet per second per second

$k_e$  = entry loss coefficient from Table C-12, Appendix C.

- (2). Exit losses are caused by the expansion of flow from the structure opening to the normal downstream channel width. The same equation for entrance losses applies to those for exit losses except  $k_e$  may be taken as **1.0** and  $V_1$  shall be defined as the velocity of flow in the downstream receiving channel after full expansion.
- (3). Friction losses are those that occur within the structure itself. These can range from open channel flow losses, and pressure flow losses, to losses caused by physical obstructions within the structure (bridge piers for example). All friction losses shall be accounted for in the analysis and design of crossing structures.

**e. Erosion and Scour Protection**

- (1). All culverts determined to be functioning under inlet control for the design discharge shall have an energy dissipation structure at the outlet of the culvert or meet the requirements of Paragraph 5e-(2) below.
- (2). The velocity of the design stormflow in the structure shall not exceed the requirements for the downstream channel condition stipulated in Table C-11, Appendix C.



**G. Floodplains****1. Principles**

<i>Floodplain Definition</i>	A “floodplain” is generally land areas along and near a waterway that are inundated during large and relatively infrequent storm events. The runoff from smaller, more frequent storm events is generally contained within the main channel of the waterway and has little to no effect on adjacent “over-bank” land areas.
<i>Width Varies</i>	Fundamentally, every watercourse has attendant floodplain areas that can be situated along one or both sides of the main channel, depending on topographic features. Along smaller streams or channels there may be little distinguishable difference between the main flow area and the floodplain. However, on larger streams or channels floodplain areas may be very broad and shallow, and may provide for very little conveyance of stormwater.
<i>Public Policy</i>	Due to rather infrequent flooding of over-bank areas and other factors, property owners often have interest in establishing urban land development in flood-prone areas, particularly in broad shallow floodplain areas. Consequently, public policy, by all levels of government, has established mechanisms designed to mitigate the negative effects of using floodplain areas. One of the purposes of these Guidelines is to facilitate those policies in the Bryan-College Station area.

**2. Identification of Floodplains**

<i>Identified Floodplains</i>	Floodplains are principally associated with the primary drainage system. The primary system and its tributaries make up the Named Regulatory Watercourses listed in Table B-1 (Appendix B) of these Guidelines. The over-bank areas of these waterways are considered to be the “identified” floodplains, even though the specific geographic limits of some reaches of each watercourse system are not dimensionally defined in hydrologic and/or topographic terms.
<i>Floodplain Limits</i>	As land development occurs along the Watercourses identified in Table B-1 (Appendix B) of these Guidelines, and along upstream extensions thereof, it will be necessary to fully define the geographic limits of the attendant floodplains. This will allow application of these Guidelines to those areas in a precise manner, thus defining hydraulic engineering needs, land development parameters, and private/public interests.

**3. Regulations**

<i>FEMA Flood Studies</i>	A series of several FEMA-approved hydrologic studies have been conducted to determine the floodplain areas along the majority of the reaches of the Named Regulatory Watercourses listed in Table B-1
---------------------------	---

(Appendix B). These are the FEMA-designated watercourses in the Bryan-College Station area. Taken together, the flood studies conducted for these Watercourses represent the "Flood Study" of the City.

<i>Areas Not Defined</i>	In some instances the floodplain areas along upper reaches of a Watercourse are undefined even though the floodplain clearly extends beyond areas shown on FEMA maps. In other instances floodplain areas may be ill-defined due to topographic or other constraints.
<i>Define Limits</i>	Land development or building projects proposed on properties astride of, or adjacent to, the Watercourses listed in Table B-1 (Appendix B) may require flood studies in order to precisely identify the elevation and geographic limits of potential floods, and thus the mitigation measures necessary for the project(s). If a proposed development will involve more than 50 lots or five (5) acres at buildout, a comprehensive flood study may be required at the discretion of the City Engineer.
<i>Special Use Areas</i>	In land areas set aside for parks or other recreational or green space uses, or proposed for such uses, special regulations by the City may require adjustments in how these Guidelines are applied. Any deviation from provisions of these Guidelines in such areas will be at the discretion of the City Engineer or his/her designee.

#### 4. Procedures

<i>If Study Needed</i>	When a comprehensive flood study is needed for a land development or building project, a number of procedures are required. The hydrologic analyses criteria and methods stipulated in Section V (Hydrology) of these Guidelines and those stipulated in Paragraph D5 of this Section will apply. For minor streams or channels that are tributaries to the Named Regulatory Watercourses, existing and ultimate flood elevations shall be established by extending the adopted Flood Study as described in foregoing Paragraph D5-d.
<i>Plot Limits</i>	Water surface elevations based on the configuration and limitations of the existing channel shall be determined for the ultimate development conditions planned by the City for the Watershed involved. The resulting geographic limits of projected flooding will be plotted by the engineer conducting the study.
<i>Channel Changes</i>	When existing channels are straightened, improved in cross-section and/or lined, existing floodplain and floodway areas are likely to be altered. Redefinition shall follow the methodology for floodway determination outlined in Paragraph G2 of this Section.
<i>Limited Effects</i>	Proposed changes in channel section or alignment shall not increase the existing or ultimate flood elevations (established by the adopted Flood Study) within, or upstream or downstream of, the area of modification, more than allowed by these Guidelines. Any changes shall be made part of the adopted Flood Study and submitted to the required authorities for approval prior to construction work in floodway or floodplain areas.

**Section VII**  
**Erosion &**  
**Sedimentation**

**Unified**  
**Stormwater**  
**Design Guidelines**

**City of College Station**  
**City of Bryan**

**August 2012**

### A. Principles

#### 1. Temporary and Lasting Measures

Measures to mitigate the effects of erosion and resulting sedimentation are divided into two categories: temporary (non-permanent) and permanent.

##### a. Non-Permanent Measures

Non-permanent (temporary) measures are designed to manage soil materials in a manner that will minimize their migration away from any land development or site improvement project during clearing, grubbing, grading, excavation, filling, and construction activities. This includes capturing sediments eroded by stormwater that traverses areas where established vegetation has been disturbed or removed, or that impacts loose materials, including stockpiles. The emphasis is on preventing sediment from being transported and deposited, by wind, water, or actions of man, onto adjacent properties, or into the primary or secondary drainage systems.

##### b. Permanent Measures

Permanent measures are designed to prevent erosion and resulting sedimentation from occurring over time, whether within earthen channels, in various facilities constructed for purposes of managing storm flow, or across unpaved land areas. Properly conceived, designed, and constructed, permanent measures can also promote the proper management of storm flow.

#### 2. Erosion Reference

A general guide and reference service for erosion and sediment control methods and protection is published by the National Resource Conservation Service (formerly Soil Conservation Service). The publication entitled "Erosion and Sediment Control Guidelines for Developing Areas in Texas" is adopted as the definitive reference for purposes of these Guidelines, and can be obtained at the address listed below. The agency can also be reached through its web site at: [www.NRCS.USDA.gov](http://www.NRCS.USDA.gov).

U.S. Natural Resource Conservation Service  
P.O. Box 6567  
Fort Worth, TX 76115

### **3. Scope of Actions**

Measures to prevent the movement of sediment by erosion or action of man shall be implemented at all areas undergoing development or construction. Positive steps shall be taken by those conducting such work to accomplish the following:

#### **a. Prevention**

Prevent the transport of sediment from all work areas onto adjacent properties or into any part of the primary or secondary drainage systems.

#### **b. Clean Up**

Promptly remove all sediment resulting from their activities if it enters onto adjacent properties or into any part of the primary or secondary drainage systems.

## **B. Non-Permanent Erosion Control Measures**

### *Methods*

Non-permanent methods to control or contain sediment materials generally fall into two categories: sediment basins and barriers. One or more methods shall be used on areas where construction activity of any kind results in earthen soils that are not covered by vegetation or impervious surfaces prior to final completion of a project.

### *Regulations*

Non-permanent erosion control measures as required by the latest regulations of the Texas Commission on Environmental Quality (formerly the Texas Natural Resource Conservation Commission) shall be used on all applicable land development or site projects approved for construction in the City. Compliance with such regulations during project construction shall be a requirement for continued operation of construction activities. Construction plans for grading, excavation, and street and utility construction in subdivision projects must include stormwater pollution prevention plans (SW3Ps).

## **C. Permanent Erosion Control Measures**

The following actions shall be incorporated into the design and construction of permanent land development or permanent improvements to properties.

### 1. Land Grading

#### a. Excavation

The cut face of earth excavation that will be in publicly maintained areas and is to be vegetated shall not be steeper than four horizontal to one vertical (4:1). Such excavated areas that will be vegetated and remain privately owned shall not be steeper than three horizontal to one vertical (3:1). Cut slopes that will not be vegetated shall be protected by approved surface treatments to protect them from erosion.

#### b. Earthen Fills

Permanent exposed faces of fills shall be no steeper than three horizontal to one vertical (3:1) and shall be vegetated or otherwise surfaced to protect them from erosion.

#### c. Runoff Management

Provisions are to be made to safely convey surface water to storm drains or suitable natural water courses and to prevent surface runoff from damaging cut faces and fill slopes.

#### d. Adjoining Properties and Facilities

##### *Near Property Lines*

Excavations shall not be made so close to property lines as to endanger adjoining property without protecting such property from erosion, sliding, settling, or cracking. No fill is to be placed where it will slide or wash onto adjacent or down stream properties, including structures.

##### *Near Channels/Streams*

No fill shall it be placed adjacent to the bank of a channel or natural stream in a manner that will allow it to migrate into the channel or stream, cause bank failure, or reduce the capacity of the channel or stream in any way.

### 2. Unpaved Areas and Swales

#### a. Stripped Areas

All areas that are graded and stripped of natural vegetative cover shall receive at least a finish layer of topsoil at least six (6) inches in depth and be seeded or covered with sod according to approved plans. The result shall be reestablishment of a protective vegetative cover capable of resisting the erosive effects of surface flow.

#### b. Swale Treatments

Earthen swales that will not be lined with hard surfaces shall be formed allowing for a finish layer of topsoil at least six (6) inches in depth and one inch of vegetation below the design invert elevations,

and shall be seeded or covered with sod according to approved plans.

### 3. Channels

#### a. Banks and Inverts

Earthen channel banks and inverts shall be treated with vegetative materials according to the requirements of the B-CS Stormwater Construction Standards.

#### b. Surface Treatments

Design velocities shall be less than the recommended maximum velocity acceptable for the proposed surface treatment as outlined in Table C-11, Appendix C. Where multiple surface treatments are to be situated in a length of channel in close enough proximity to have interactive effects, the limiting velocity shall be the minimum recommended value among those representing the proposed surface treatment types.

#### c. Supercritical Flow

Channels designed to function with supercritical flow shall be fitted with lining and energy dissipation features adequate to handle the resulting velocities and hydraulic jumps.

#### d. Channel Protection

The integrity of channel linings and cross sections shall be protected at all locations where stormwater enters a channel from other stormwater facilities. See "Outfall Junctions" in Section VI, Paragraph D3-c of these Guidelines.

### 4. Energy Dissipation

Energy dissipation features are required at any point where stormflow design velocities are expected to exceed the surface erosion characteristics of the receiving facility, or empirical criteria established elsewhere in these Guidelines.

#### a. Allowable Velocities

Design velocities shall be less than the recommended maximum velocity acceptable for the proposed surface treatment as outlined in Table C-11, Appendix C.

#### b. Examples Designs

Acceptable configurations for energy dissipation structures at outfall structures and channels are reflected in B-CS Technical Specifications, but other special designs will be considered.

Designs suitable to specific situations are encouraged. Reinforcing steel shall be designed to resist the anticipated hydraulic, hydrostatic, dead, and live loads for the structures.

**c. Natural Dissipation Features**

Energy dissipation features designed to replicate those occurring due to interaction between stormflow and the stream bed along natural streams are encouraged. Plunge pools in series, stilling “basins”, surfaces, and vegetative materials are examples of elements that might be used in combination to achieve such designs.

**5. Best Practices**

Managing erosion and sediment must be an integral part of designing effective stormwater management and conveyance systems for urban areas. Design techniques are subject to ongoing development and assessment, particularly from the standpoint of environmental quality. Consequently, if special designs call for deviation from the empirical criteria (and the traditional design approach) promulgated by these Guidelines, the following reference is recommended:

Storm Water Phase II Menu of Best Management Practices, published by the US Environmental Protection Agency (EPA).



**Section VIII**  
**Water Quality**

**Unified  
Stormwater  
Design Guidelines**

**City of College Station  
City of Bryan**

**August 2012**

### **A. Principles**

#### *Polluted Runoff*

It is well understood that stormwater runoff in urban and suburban environments tends to carry an assortment of sedimentation and pollutants into the streams and waterways that drain a region. The nature of those materials depends on numerous variables. Among them are the type and intensity of land use in the areas drained, the characteristics of rainfall flushing those areas, the urban development parameters used, and the effects of natural or specially deployed features that work to enhance or aggravate the quality of storm runoff.

#### *Design Effects*

Based on scientific information derived and promulgated at the State and National levels, it is clear that hard surfaces that quickly drain areas tend to do nothing to enhance the quality of stormwater runoff. Likewise, stormflow across exposed earthen areas tends to carry undesirable sediment loads. Conversely, runoff that first travels through or over turf, wetland, or sedimentation features tends to transport smaller quantities of undesirable materials. For this reason one of the objectives of these Guidelines is to encourage the use of innovative facilities that minimize adverse affect(s) on water quality, provided the primary objective of protecting life and property is not compromised.

#### *Known Problems*

Where persistent, known drainage problems exist, the primary focus must necessarily be on promoting public safety and minimizing flooding of property. In such areas improving the quality of storm runoff will be a carefully considered in light of public safety objectives.

### **B. Imbedded Objective**

#### *Foster Water Quality*

One of the objectives of these Guidelines is to foster improvement of the quality of stormwater runoff in the Bryan – College Station region. Part of the intent is to cause water draining from newly developing areas to carry smaller amounts of pollutant loads than would occur under former guidelines.

#### *Design Encouraged*

Water quality objectives are clearly delineated in policy statements in Section II, and in the sedimentation control guidance outlined in Section VII. They are also imbedded in Section VI in two areas of hydraulic design. Special designs aimed at improving stormwater quality are encouraged for detention facilities and at points where traditional facilities outfall to streams and waterways. In some instances such designs may be less expensive to construct than traditional stormwater features.

#### *Early Teams*

Special water quality designs must be coordinated with the City Engineer or his/her designee as early as possible in design processes, preferably during the stormwater planning conference described in Section III. Emphasis is placed on use of qualified specialists for

deriving designs intended to reduce pollutant loads. This is important because long term maintenance needs and cost may not be exacerbated by such designs.

*SW3P Required*

As stipulated in Section VII of these Guidelines, non-permanent erosion and sedimentation control measures are required during construction projects. The latest requirements of the TCEQ must be satisfied.

### **C. Regulatory Context**

The quality of storm runoff into streams and waterways is regulated by law in several ways both at the National and State levels.

#### **1. National Regulations**

##### **a. Section 10 Rivers and Harbors Act**

*Navigable Waters*

Section 10 of the Rivers and Harbors Act of 1899 places jurisdiction over certain waters squarely in the hands of the Federal Government. The US Army Corps of Engineers (USACE) operates a regulatory program under the authority of this and subsequent law. This deals with the “navigable waters of the United States”. “Navigable waters” are those that are subject to the ebb and flow of the tide shoreward to the mean high water mark and/or are presently used, or have been used in the past or may be susceptible to use, to transport interstate or foreign commerce. The Brazos River and its tributaries (with some limitations) are included in this definition.

*Basic Provisions*

The Corps of Engineers regulates all work and structures in, or affecting, the course, condition, or capacity of navigable waters of the United States. Example activities and structures include dredging, filling, excavation, bulkheads, revetments, riprap, and pilings. This has obvious application to roadway crossings, on line or adjacent detention facilities, and most types of earthwork along the banks of applicable watercourses.

##### **b. Section 404 Clean Water Act**

*Waters Of The US*

Administered jointly by the USACE and the Environmental Protection Agency (EPA), Section 404 has the objective of restoring and maintaining the chemical, physical, and biological integrity of the “waters of the United States”. This deals with the surface water tributary system. It includes the smallest of streams, any lake, pond, or other water body on those streams, and adjacent wetlands. Under this Act the US Army Corps of Engineers has certain regulatory powers.

*Basic Provisions*

The Corps of Engineers’ Wetland Delineation Manual provides guidelines for determining whether wetland areas are regulated by

Section 404. Placement of dredged or excavated materials into waters of the US is regulated. This includes the addition of material associated with mechanized land clearing, ditching, channelization, side-casting, temporary stockpiling, and other ground-disturbing activities, especially if materials have the effect of replacing water or wetland environments, or changing the bottom elevation of waters of the US.

### c. Section 401 Clean Water Act

#### *Point Sources*

Dating from 1977, Section 401 established permitting requirements for allowing discharges of effluent into navigable waters of the US. The focus was on permitting for construction of plants or facilities that would discharge potentially polluted water, primarily from point sources, as from food processing, industrial processes, or waste treatment. Later legislation began applying water quality regulation to stormwater runoff.

### d. Section 402 Clean Water Act

#### *Stormwater Quality*

In 1987 the US Congress amended Section 402 of the Clean Water Act regarding administration of the National Pollutant Discharge Elimination System (NPDES). As to the quality of stormwater discharge, a comprehensive two-phased permitting framework was initiated for dealing with “municipal separate storm sewer systems”. “Separate” is important because it differentiates between systems that collect and discharge only storm runoff from those that may include effluents from such sources as sewage treatment or industrial processes. Fundamentally, it requires municipalities to initiate comprehensive programs for minimizing pollutant loads discharged into streams and waterways.

#### *Phases I & II*

Phase I regulates large and medium “municipal separate storm sewer systems” (MSSSS or MS4). Municipalities having a population in excess of 100,000 are known as “Phase I MS4s”. These have been required to implement some system of practices designed to improve the quality of stormwater discharges. Under Phase II rules issued by the EPA in 1999, smaller MS4s must also be in compliance with NPDES requirements. Smaller MS4s are defined as municipalities having less than a population of 100,000 and located in “urbanized areas” as defined by the US Census. These are known as “Phase II MS4s”. Both Bryan and College Station are in this category.

## 2. State Of Texas Regulations

In 1998 administration of the National Pollutant Discharge Elimination System (NPDES) was partially delegated by the Environmental Protection Agency, via a memorandum of understanding, to the State of Texas. However, the EPA retains its enforcement authority.

### a. Texas Administrative Code (30 TAC, Chapter 319)

## SECTION VIII

### WATER QUALITY

#### *Texas Waters*

The Texas Commission on Environmental Quality (TCEQ) is the State agency responsible for the quality of "Waters of the State", including stormwater quality. Since 1998 stormwater quality has been regulated pursuant to the Texas Pollutant Discharge Elimination Program administered by TCEQ. Prior to that, individual permits were issued to larger MS4s by the EPA, but since 2002 the TCEQ has issued renewal permits and addressed various issues for those MS4s. The TCEQ has responsibility for administering Phase II permitting. This will include designating small MS4s, developing a template general permit, providing suitable BMPs for use by municipal entities, and administering the permitting process.

#### *Requirements*

Under Phase II requirements, small MS4s are required to reduce the discharge of pollutants to the maximum extent practicable. MS4s are to accomplish this by developing and implementing a Stormwater Management Program (SWMP) for their jurisdiction. Each local SWMP is to deploy acceptable BMPs that use the six minimum control measures listed in Paragraph C1-d above. The intent is to provide general permitting to MS4s that deploy an acceptable SWMP, thereby avoiding the need for an individual permit from the TCEQ.

#### **b. Permitting Requirements**

Although Phase II requirements for small MS4s have been established by the EPA, the TCEQ remains in the rule-making phase.

Pursuant to the Texas Pollutant Discharge Elimination System (TPDES) permit issued by the Texas Commission on Environmental Quality (TCEQ) to the City of Bryan and the City of College Station for the Municipal Separate Storm Sewer System (MS4), the Cities are implementing these guidelines. The purpose of these guidelines is to satisfy the requirements promulgated in the TPDES permit regarding the implementing of a program to reduce the discharge of pollutants into the Cities MS4.

Construction site activities shall be conducted in a manner as to meet the minimum requirements mandated in the [TPDES General Permit No. TXRI50000](#). The General Permit is required by the TCEQ for any construction activities.

[Less than 1 acre disturbance](#)

[1 to 5 acres disturbance](#)

[Greater than 5 acres disturbance](#)

List of Best Management Practices **not** approved by the City of Bryan or the City of College Station are as follows:

- Oil / Grit Separators
- Traditional Sand bags for inlet protection (environmental control socks are preferred)

**BEST MANAGEMENT PRACTICES – STORMWATER QUALITY CONTROLS**

	<b>Construction Stages / Sequencing</b>	<b>Non-Structural</b>	<b>Structural</b>
1	Pre-construction / Survey clearing / limited ground disturbance	<ul style="list-style-type: none"> <li>• Establishment of Trees to protect (if desired)</li> <li>• Limited equipment (no tracked equipment)– no significant ground vegetation disturbance</li> </ul>	
2	Install Detention Facilities – rough graded to capture runoff	<ul style="list-style-type: none"> <li>• Install waste receptacles on site</li> <li>• Temporary Sanitary Facilities (port-a-potties)</li> <li>• Designate concrete / equipment washout area</li> <li>• Install Temporary Construction Access</li> <li>• Install storm sewer inlet protection (existing inlets)</li> </ul>	<ul style="list-style-type: none"> <li>• Silt Retention Devices (ex. Silt fence, check dams)</li> <li>• Sedimentation Traps / ponds / baffles</li> <li>• Rough grade detention ponds</li> <li>• Outlet structure installed</li> <li>• Slope protection measures</li> </ul>
3	Full Clearing and Grading	<ul style="list-style-type: none"> <li>• Dust Control (wetting disturbed areas) (daily)</li> <li>• Street Sweeping (daily)</li> </ul>	<ul style="list-style-type: none"> <li>• Maintain Silt Retention Devices</li> <li>• Rough Grade property to drain to ponds</li> <li>• Slope protection measures</li> </ul>
4	Utility Infrastructure & Drainage System	<ul style="list-style-type: none"> <li>• New Storm inlet protection</li> <li>• Proper directing of rainwater pumping from construction ditches</li> </ul>	<ul style="list-style-type: none"> <li>• storm sewers / inlets</li> <li>• Detention Pond</li> <li>• Onsite Utilities installed</li> </ul>
5	Site Development (buildings)	<ul style="list-style-type: none"> <li>• Utilize washout areas</li> <li>• Maintain trash and sanitary facilities</li> <li>• Installation of roof gutters directed to storm system</li> <li>• Dust Control (wetting disturbed areas) (daily)</li> <li>• Street Sweeping (daily)</li> </ul>	<ul style="list-style-type: none"> <li>• Install paving on site (minimize erosion) – done before building foundations</li> </ul>
6	Site Stabilization	<ul style="list-style-type: none"> <li>• Maintenance Bond (1 year) provided to cover public infrastructure and final site stabilization</li> </ul>	<ul style="list-style-type: none"> <li>• Full grass / landscape coverage and establishment</li> <li>• Removal of silt retention devices upon grass establishment</li> </ul>

### **c. Compliance**

Compliance with the above General Permits is required. The City of Bryan and the City of College Station have the authority to enforce compliance with the General Permit including the SWPPP prepared for each development. Copies of Notice of Intent, Construction Site Notices, Notice of Change and Notice of Termination along with the SWPPP shall be submitted to the City Engineer's office.

# **Section IX**

## **Appendices**

### **Unified Stormwater Design Guidelines**

**City of College Station  
City of Bryan**

- A. Authority**
- B. Region's Watersheds**
- C. Computational Information**
- D. Technical Design Summary**
- E. Best Practice**
- F. Glossary**
- G. General References**

**AUGUST 2012**



# **Appendix A Authority**

## **Unified Stormwater Design Guidelines**

**City of College Station  
City of Bryan**

**AUGUST 2012**

# **SECTION IX**

## **APPENDIX A – AUTHORITY**

These Uniform Stormwater Design Guidelines regulate the design philosophies and criteria that are to be used in assessing the need for and design of stormwater management facilities planned and engineered for land development projects within the jurisdictions of the City of Bryan and the City of College Station. Important purposes are: 1) to offer the citizens of the both cities a single set of requirements that clearly define what must be done to satisfy the broad policies of each city, and, 2) to achieve greater uniformity of resulting stormwater facilities. To those ends, these Guidelines work to implement stormwater management ordinances adopted respectively by the City of Bryan and the City of College Station for use in their respective jurisdictions.

These Guidelines derive their authority from the stormwater management ordinances and floodplain management ordinances adopted from time to time by the City Council of each of the two cities. The respective ordinances are referenced below.

### **City of Bryan:**

Stormwater Management Ordinance, adopted via Ordinance No. 669,  
September 28, 1987, as amended:  
    Ordinance No. 849 – October 27, 1992 (effective November 26, 1992)  
    Ordinance No. 1156 – January 26, 1999

~~~~~

Codified Municipal Ordinance: Chapter 10 – Flood Prevention and  
Protection

### **City of College Station:**

~~~~~

Codified Municipal Ordinance: Chapter 13 – Flood Hazard Projection

# **Appendix B**

## **Region's Watersheds**

### **Unified Stormwater Design Guidelines**

**City of College Station  
City of Bryan**

**AUGUST 2012**

# SECTION IX

## APPENDIX B – REGION’S WATERSHEDS

**Table B-1**  
**Detention Requirements by Watershed and Watershed Reach**

Reference Section II, Paragraph B, page 2 of 18

Watershed Name	Channel Reach		Detention For Flood Control
	From	To	
Alum Creek	Carter Creek	SH 6	Not Required
	SH 6	Upstream	Required
Bee Creek	Carter Creek	Texas Avenue	Not Required
	Texas Avenue	Southwest Parkway, Welsh, Deacon	Evaluate
	Southwest Parkway, Welsh, Deacon	Upstream	Required
Briar Creek	Carter Creek	Quail Hollow, SH 6	Not Required
	Quail Hollow, SH 6	E. Villa Maria	Evaluate
	E. Villa Maria	Upstream	Required
Brushy Creek	Wickson Creek	Cole Lane	Not Required
	Cole Lane	Elmo Weedon Road	Evaluate
	Elmo Weedon Road	Upstream	Required
Burton Creek	Carter Creek	E. 29 <sup>th</sup> Street	Not Required
	E. 29 <sup>th</sup> Street	E. Villa Maria	Evaluate
	E. Villa Maria	Upstream	Required
Carters Creek	Navasota River	Upstream	Evaluate
Cottonwood Branch	<i>Thompson’s Creek</i>	FM 2818	Evaluate
	FM 2818	Upstream	Required
Hudson Creek	Carter Creek	Boonville Road	Not Required
	Boonville Road	Miramont	Evaluate
	Miramont	Upstream	Required
Lick Creek	Navasota River	Greens Prairie Road	Not Required
	Greens Prairie Road	SH 6	Evaluate
	SH 6	Upstream	Evaluate
Little Wikson Creek	Wickson Creek	Dilly Shaw Tap Road	Evaluate
	Dilly Shaw Tap Road	Upstream	Required
Peach Creek	Navasota River	Peach Creek Road	Not Required
	Peach Creek Road	Upstream 14,000 feet	Evaluate
	14,000 ft. above Peach Creek	Upstream	Required
Spring Creek	Lick Creek	SH 6	Evaluate
	SH 6	Upstream	Required

# SECTION IX

## APPENDIX B – REGION'S WATERSHEDS

### Table B-1 (continued)

#### Detention Requirements by Watershed and Watershed Reach

Reference Section II, Paragraph B1, page 2 of 18

Watershed Name	Channel Reach		Detention For Flood Control
	From	To	
Steep Hollow Branch	Wickson Creek	Green Branch Loop, Easterling Drive	Evaluate
	Green Branch Loop, Easterling Drive	Upstream	Required
Still Creek	Thompsons Creek	FM 2818	Evaluate
	FM 2818	Upstream	Required
Thompsons Branch	Thompsons Creek	N. Texas Avenue	Evaluate
	N. Texas Avenue	Upstream	Required
Thompsons Creek	Brazos River	SH 21	Not Required
	SH 21	Thompsons Branch	Evaluate
	Thompsons Branch	Upstream	Required
Turkey Creek	Brazos River	SH 47	Not Required
	SH 47	W. Villa Maria Drive	Evaluate
	W. Villa Maria Drive	Upstream	Required
White Creek	Brazos River	Unnamed Road off White Creek Road	Not Required
	Unnamed Road off White Creek Road	FM 2818	Evaluate
	FM 2818	Upstream	Required
Wolf Pen Creek	Carter Creek	Dartmouth Street	Not Required
	Dartmouth Street	George Bush Drive at Texas Avenue	Evaluate
	George Bush Drive at Texas Avenue	Upstream	Required

# SECTION IX

## APPENDIX B – REGION’S WATERSHEDS

**Table B-2**

**Minimum Floor Elevations Along Selected Named Regulatory Watercourses**

Reference Section II, Paragraph C1-b, page 8 of 18

Regulatory Watercourse	Channel Reach		Elevation Above Base Flood
	From	To	
Bee Creek (Main Watercourse)	Bee Creek Trib. B	Texas Ave.	3 feet
Bee Creek Trib. "A"	Walsh Ave.	Main Bee Creek below* East Bypass	2 feet
Bee Creek Trib. "B"	South Fork Trib. "B" above Welsh Ave.	FM 2818	4 feet
	FM 2818 at Rio Grand	Main Bee Creek	2 feet
	North Fork Trib. "B" at FM 2818 and at Southwest Parkway	South Fork Trib. "B" near Welsh Ave.	2 feet
	South Fork Trib. "B" at Wellborn Road	Bee Creek Trib. "B"	2 feet
Lick Creek	Graham Road	Alum Creek confluence	3 feet
South Fork of Lick Creek	First trib. above CS city limits	Main Lick Creek	3 feet
Spring Creek	Confluence of North and South Forks	Main Lick Creek	3 feet
North Fork of Spring Creek	Upper limits	Confluence with South Fork	3 feet
South Fork of Spring Creek	Upper limits	Confluence with North Fork	3 feet

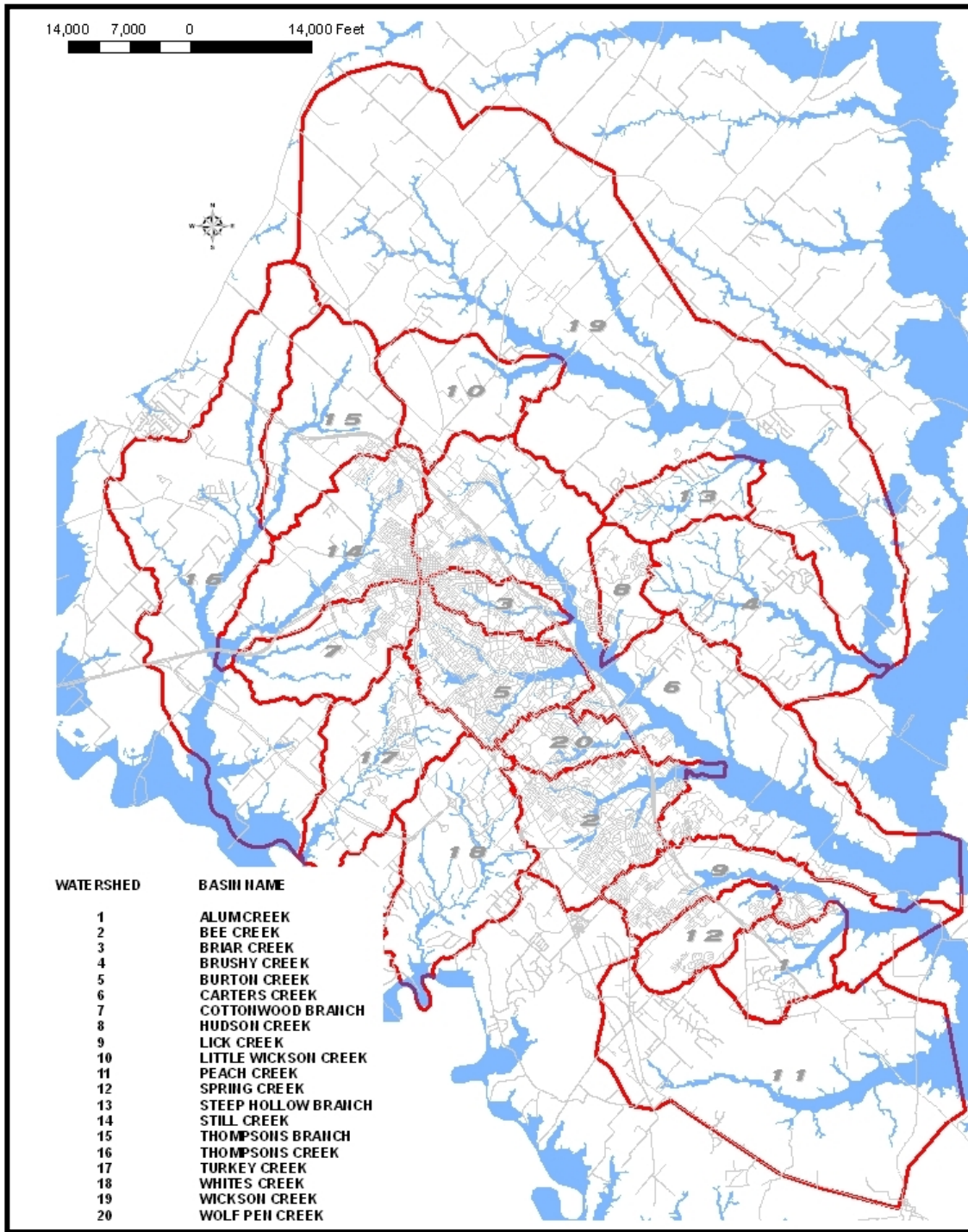

Figure B-1: Watersheds of Bryan / College Station Region

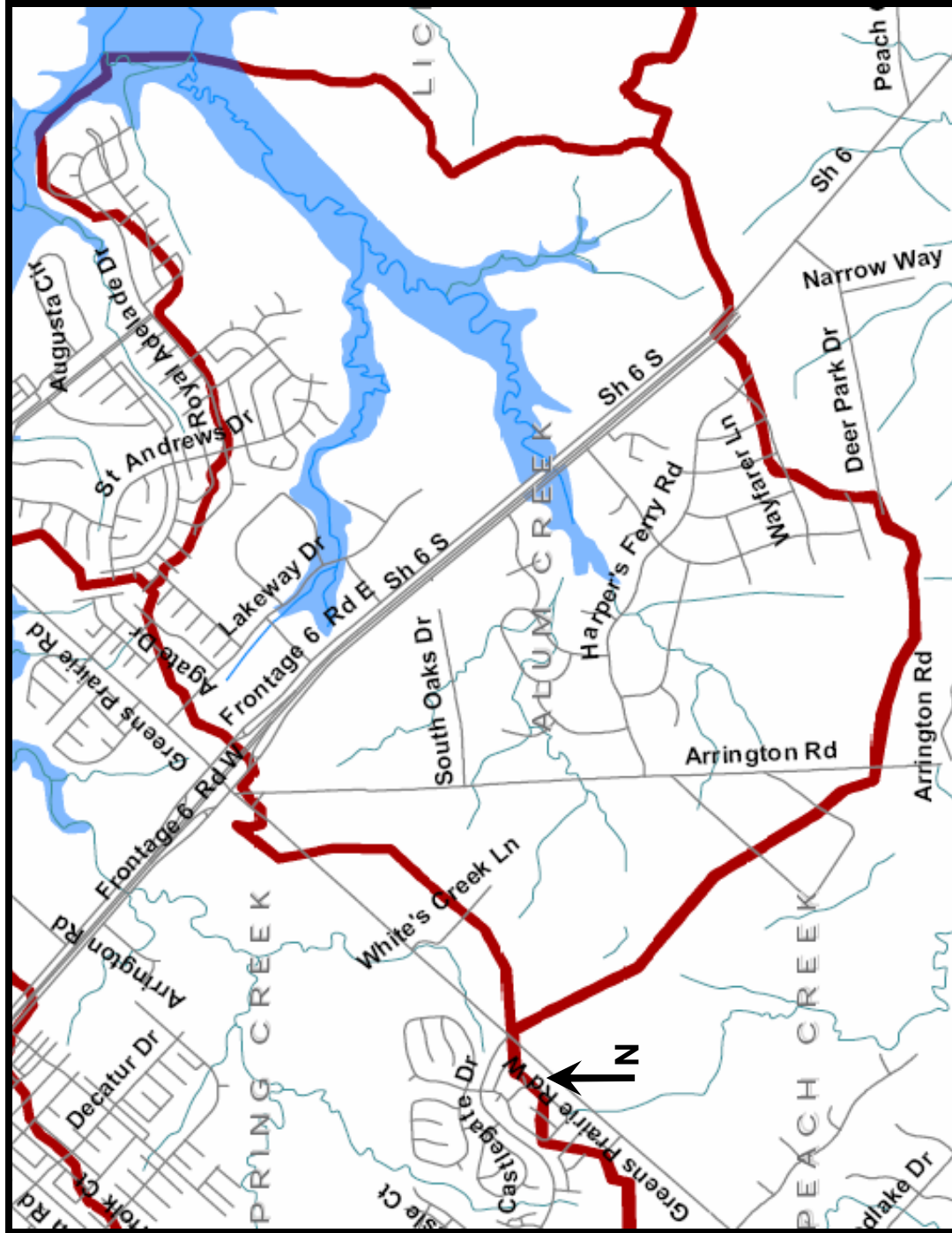

Figure B-2: Alum Creek Watershed Area



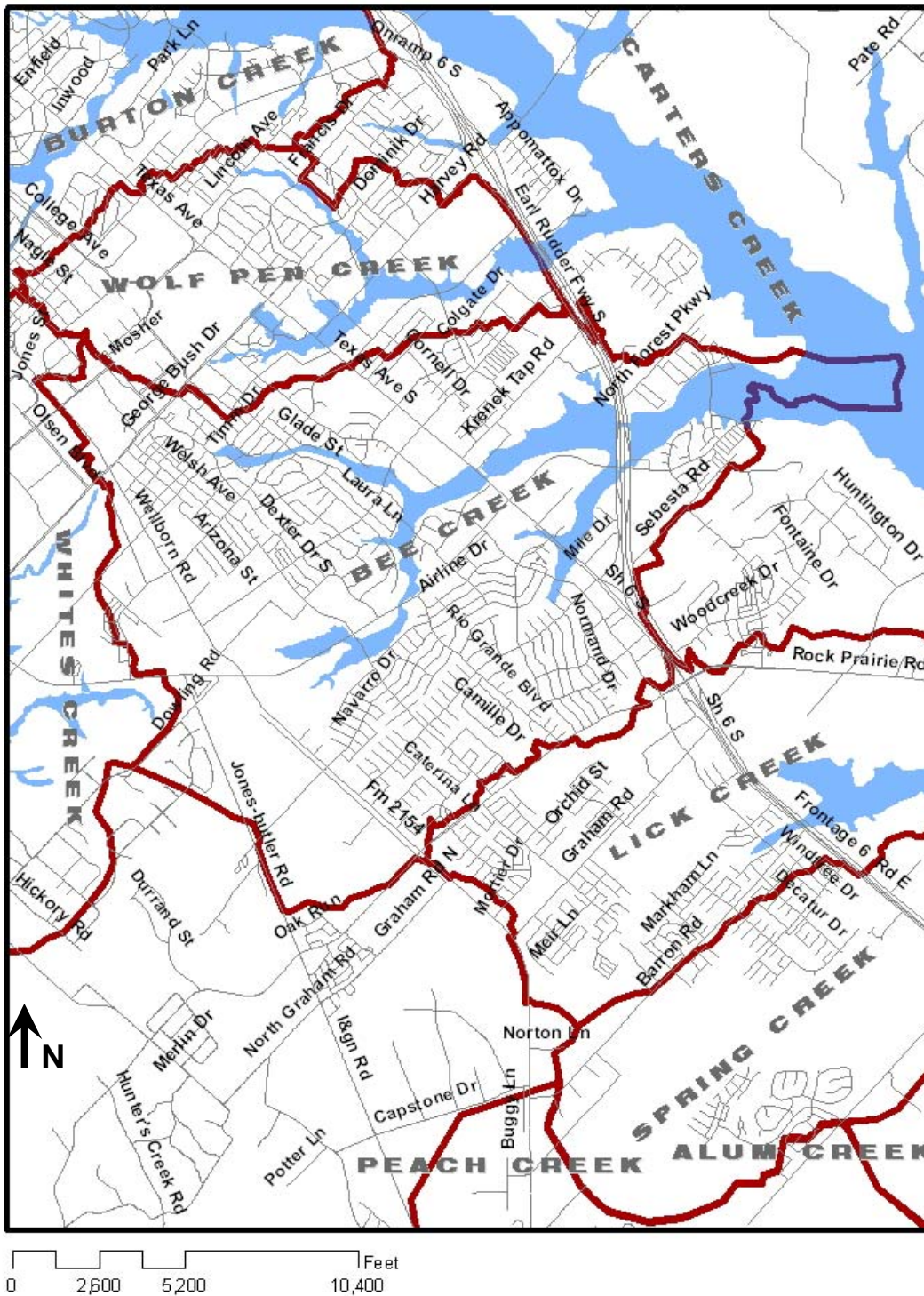

Figure B-3: Bee Creek Watershed Area

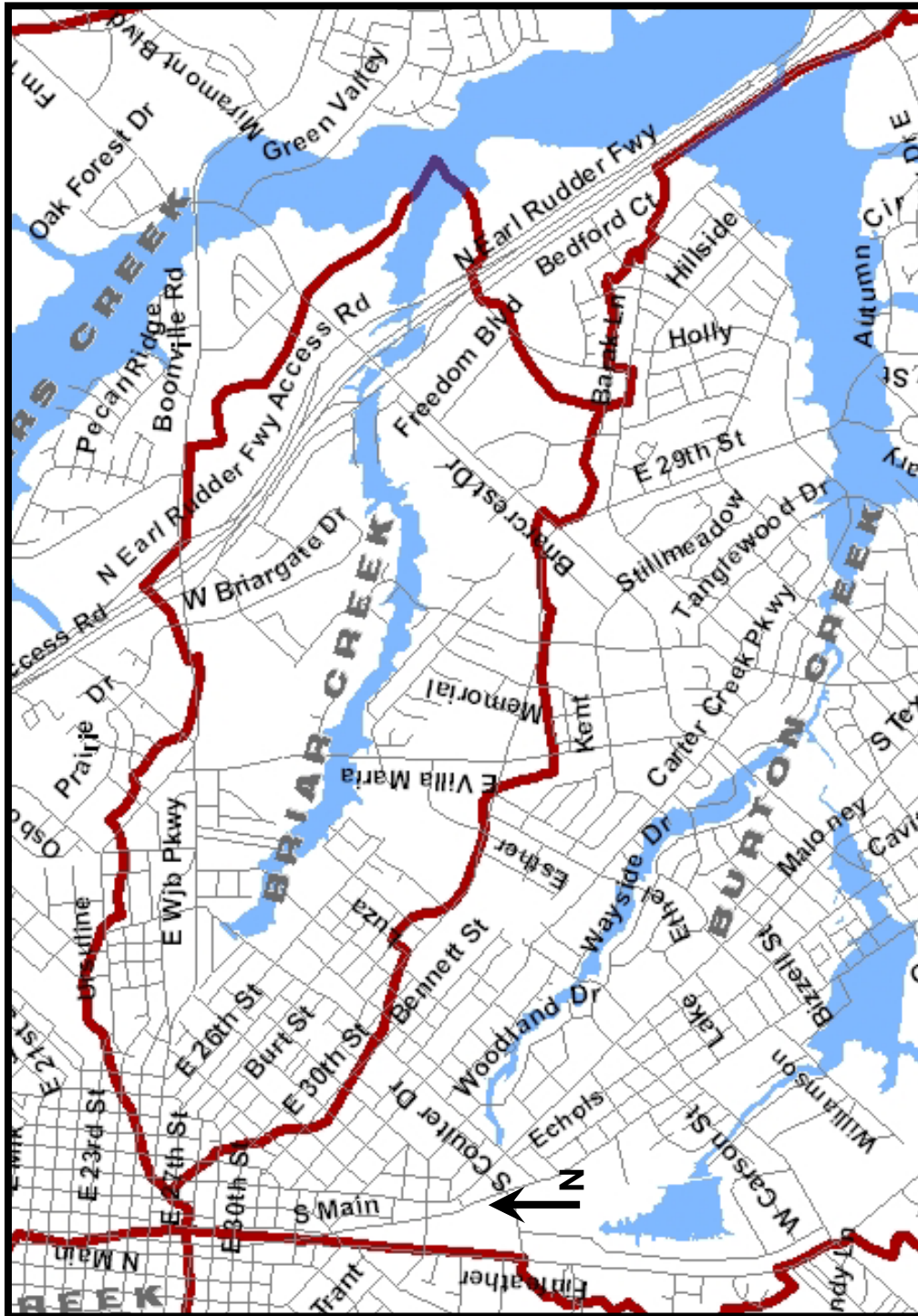

Figure B-4: Briar Creek Watershed Area

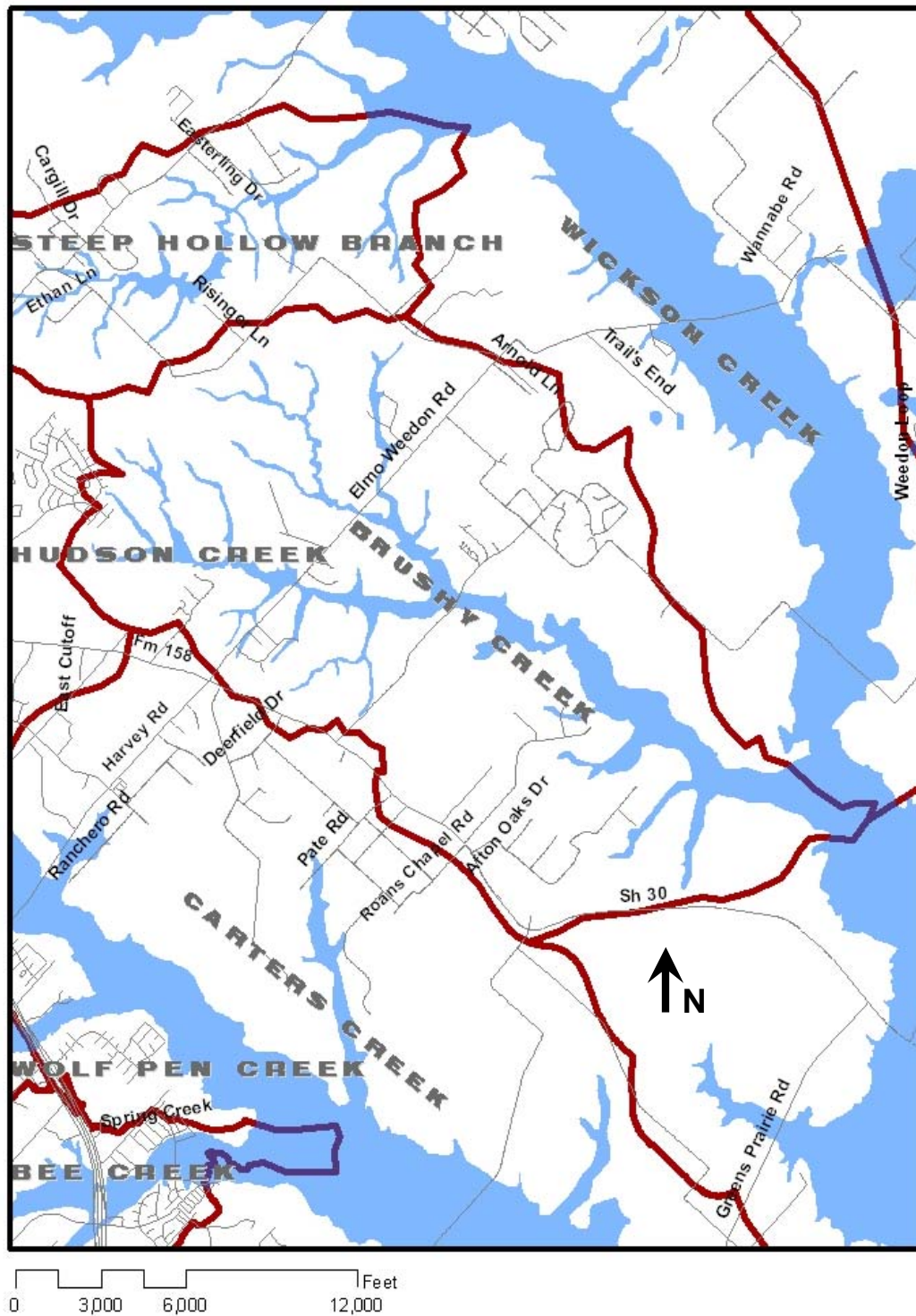

Figure B-5: Brushy Creek Watershed Area

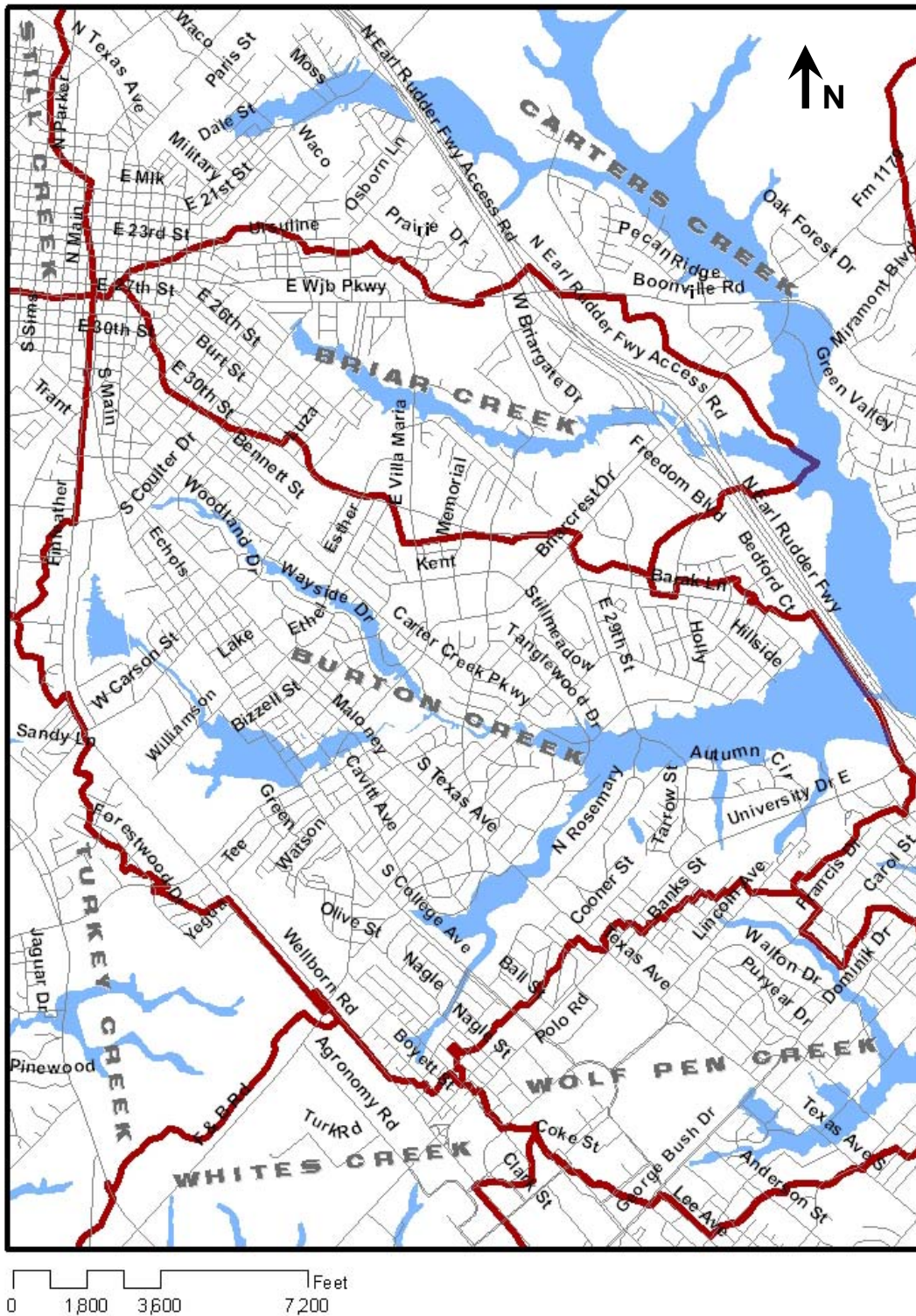

Figure B-6: Burton Creek Watershed Area

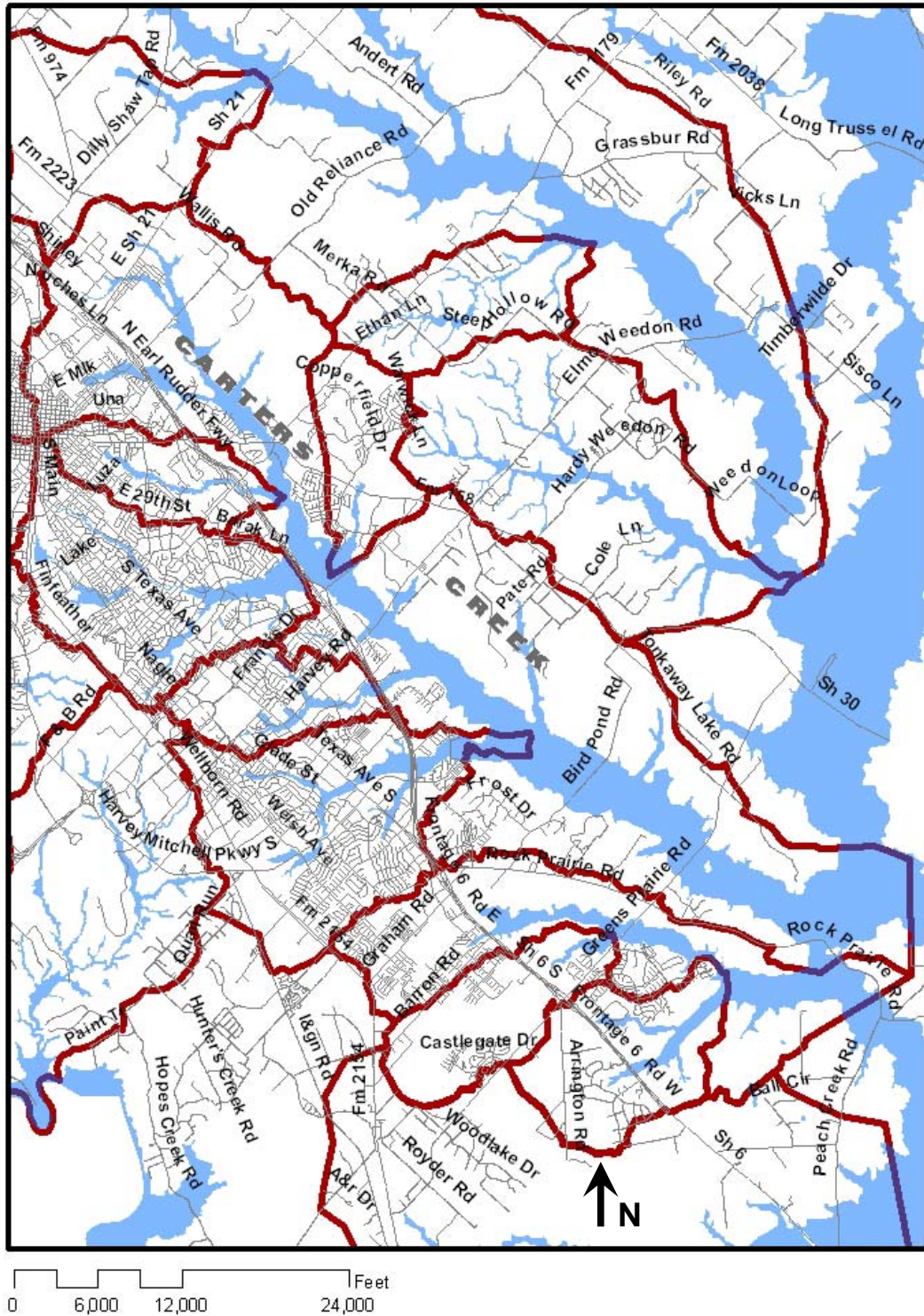

Figure B-7: Carters Creek Watershed Area

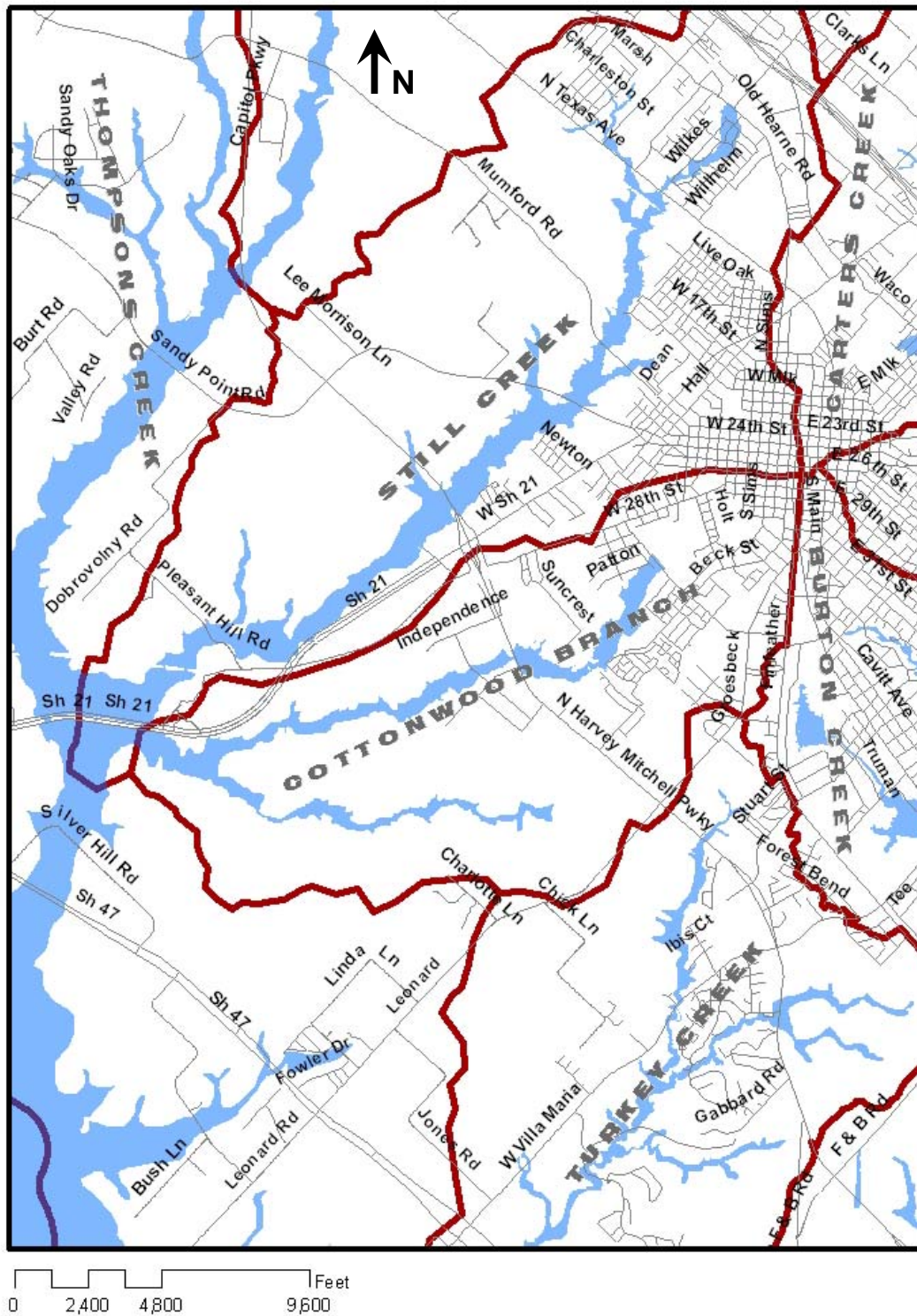

Figure B-8: Cottonwood Branch Watershed Area

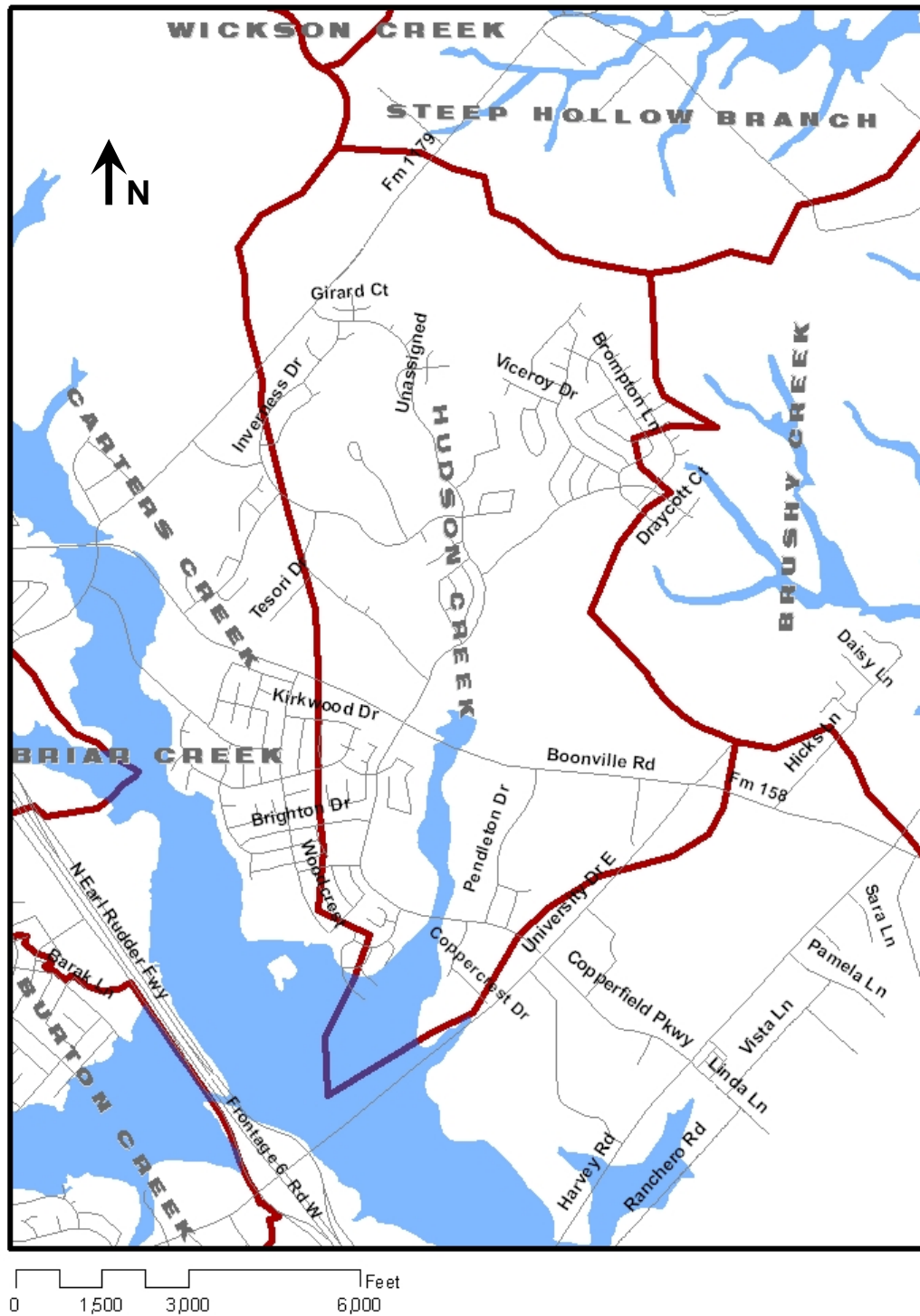

Figure B-9: Hudson Creek Watershed Area

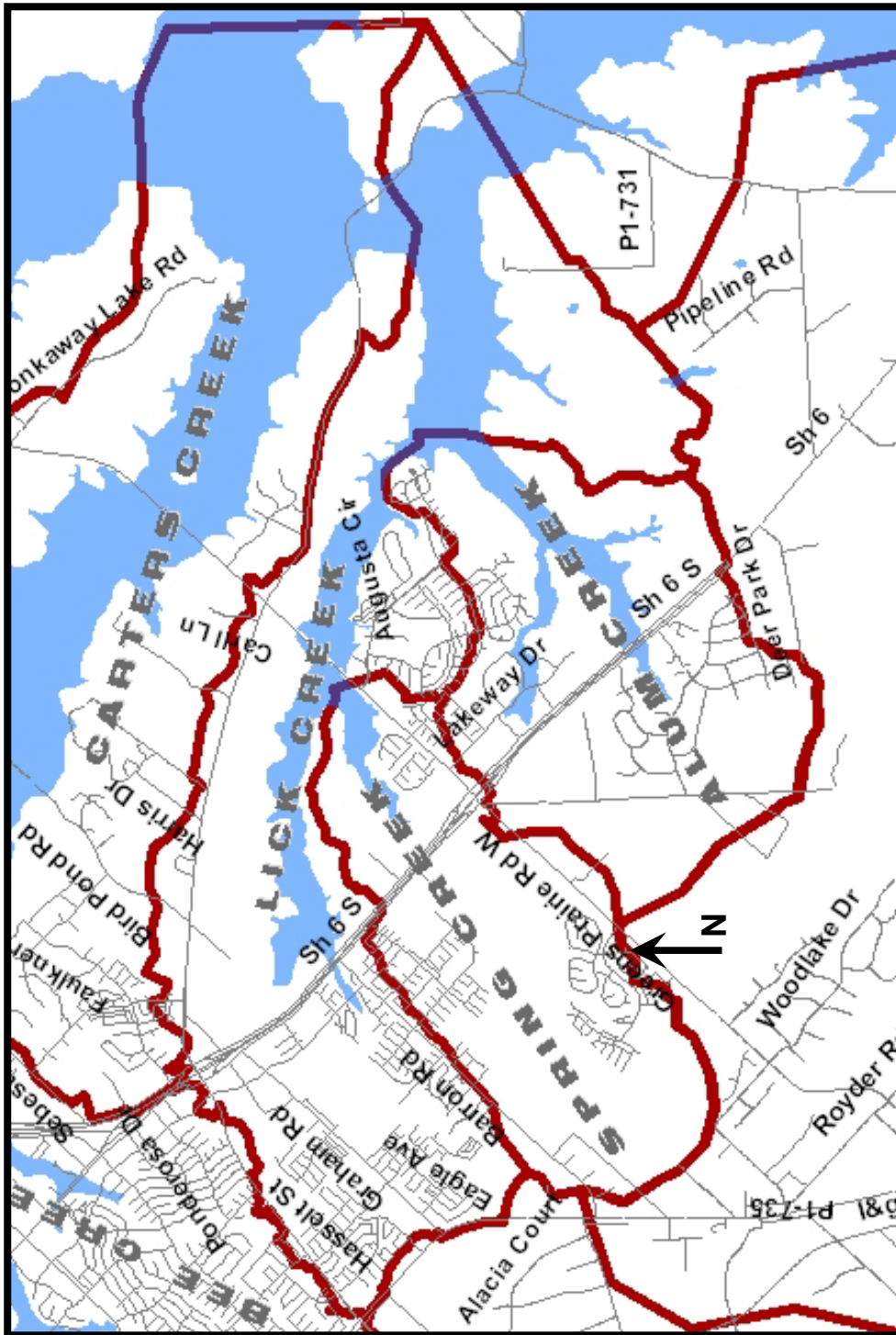

Figure B-10: Lick Creek Watershed Area





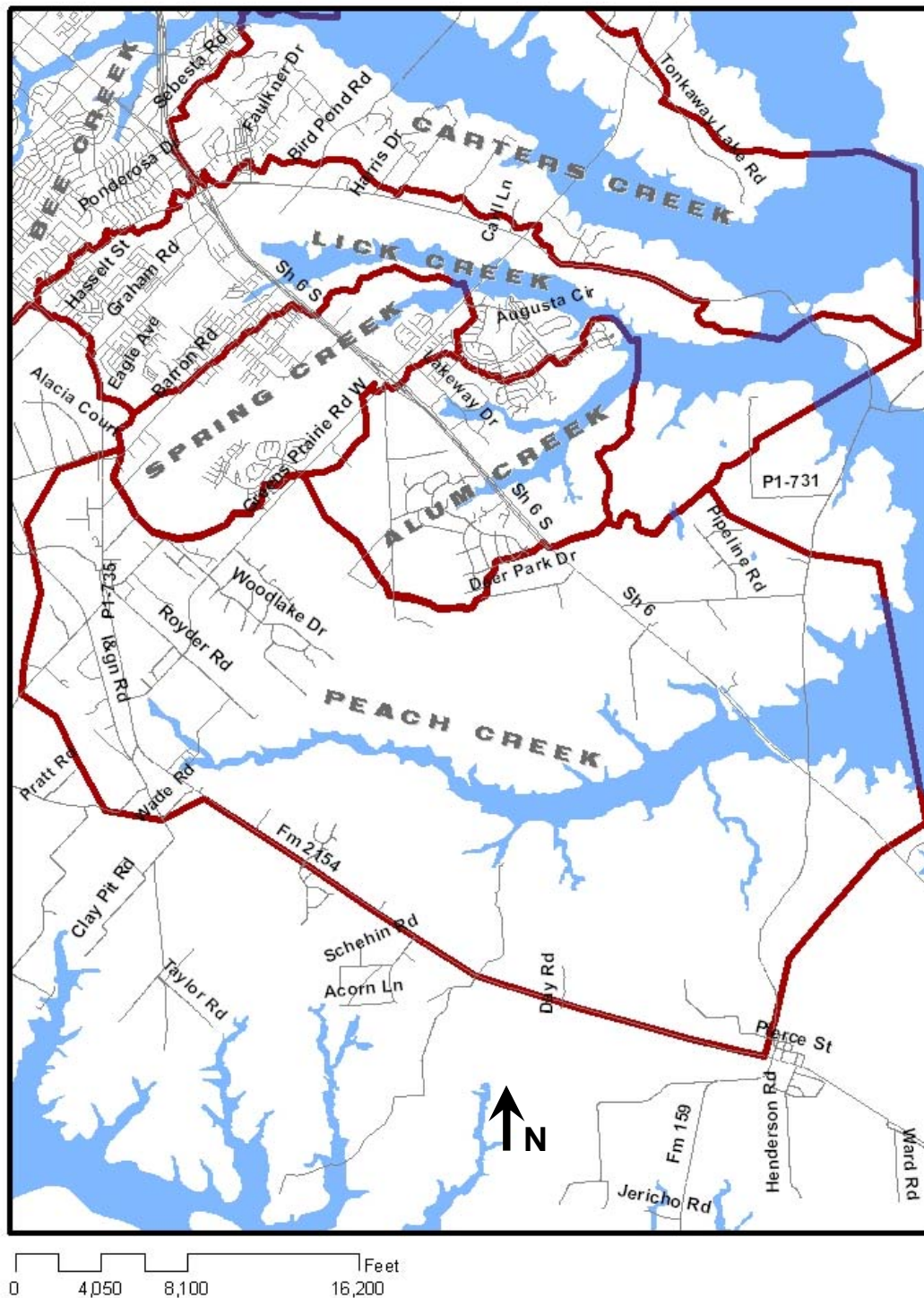

Figure B-12: Peach Creek Watershed Area

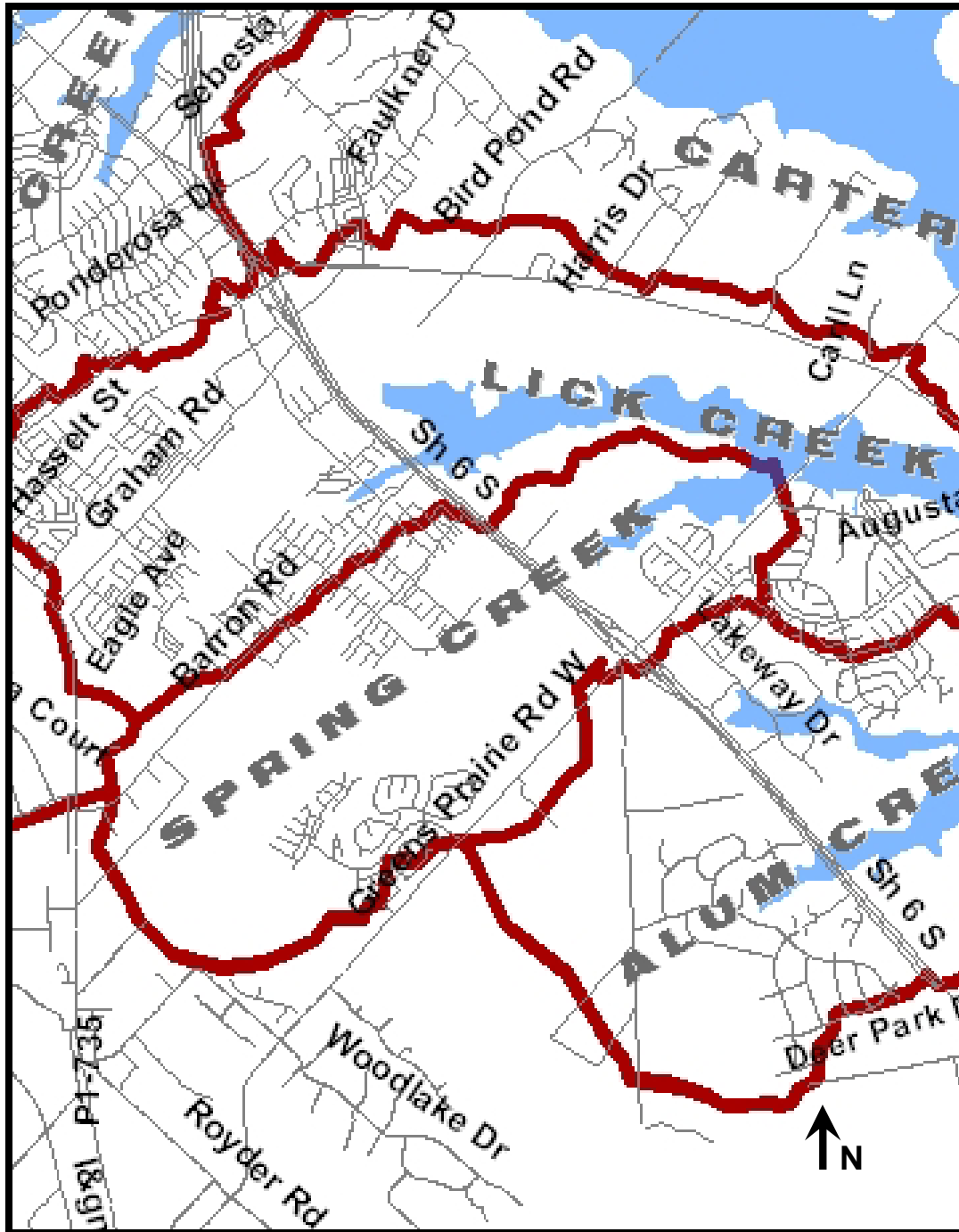

Figure B-13: Spring Creek Watershed Area

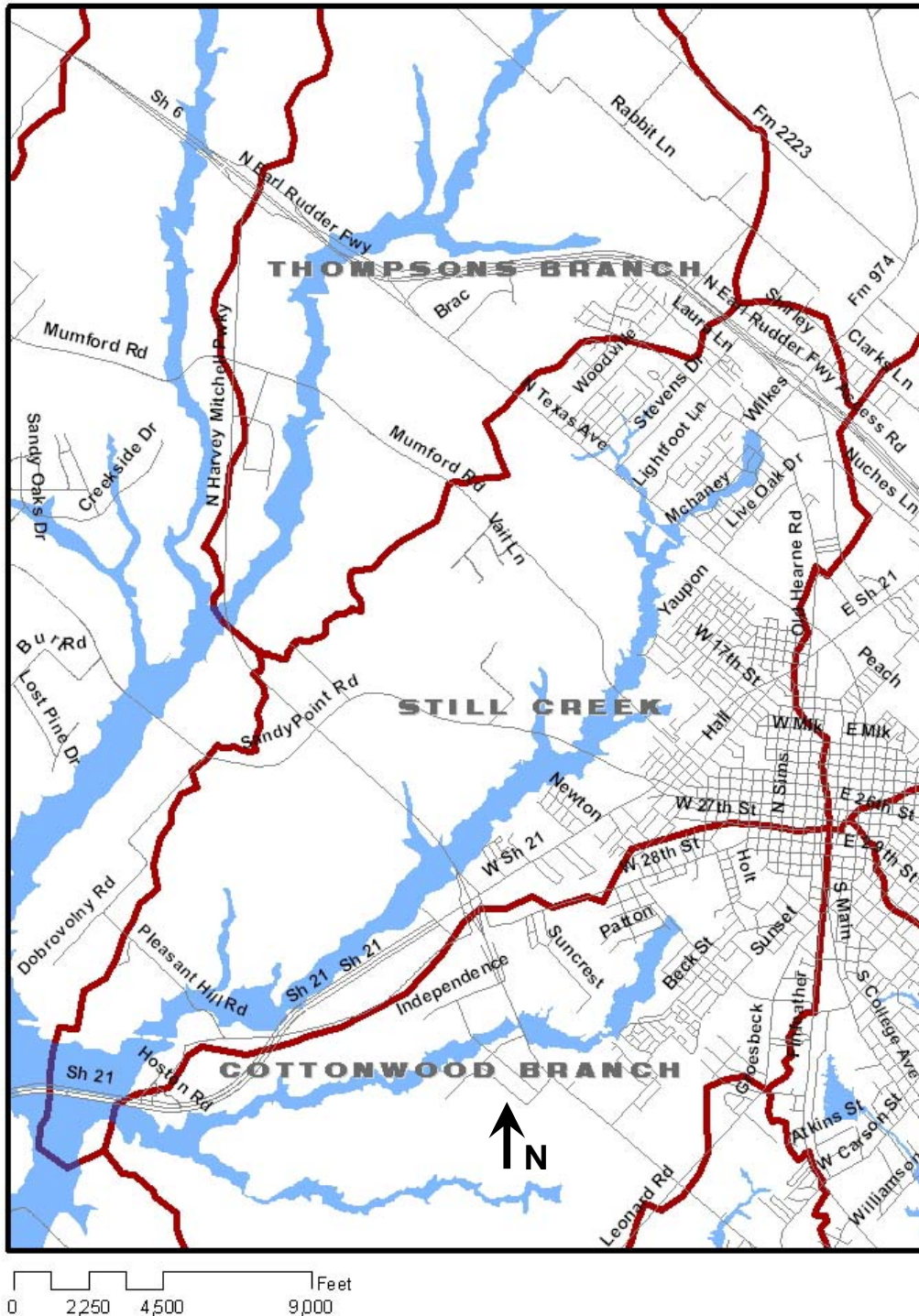

Figure B-14: Still Creek Watershed Area

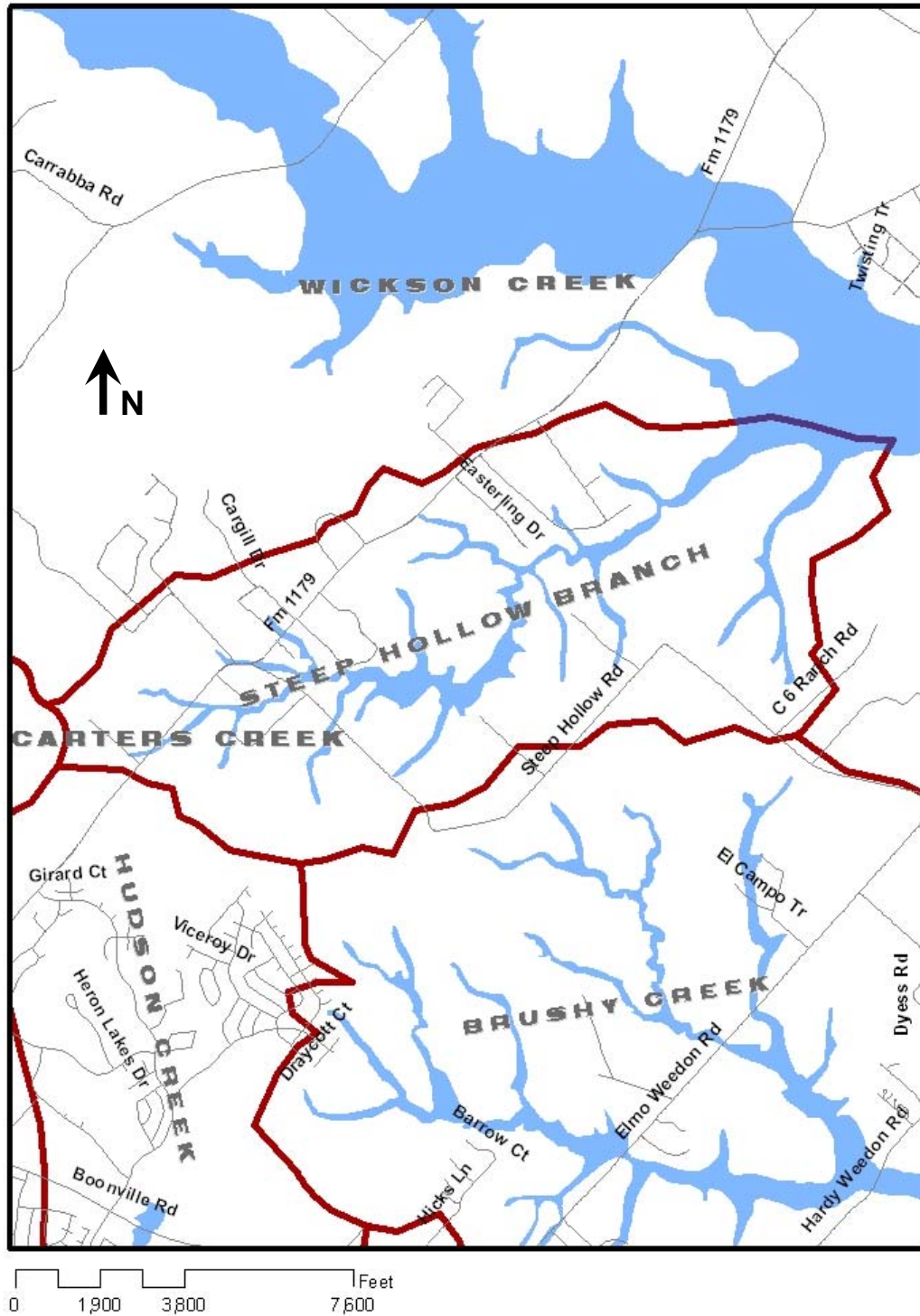
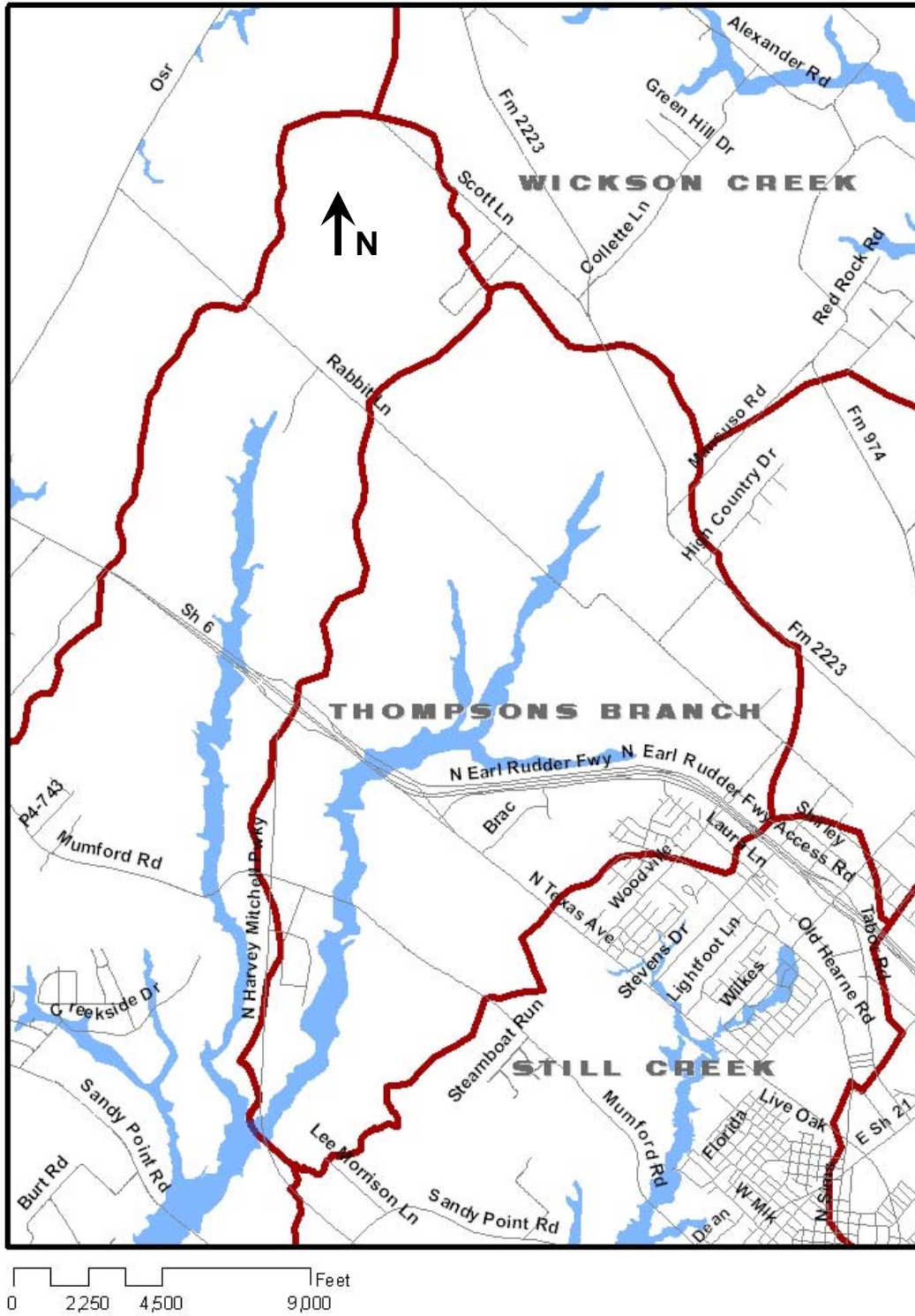

Figure B-15: Steep Hollow Branch Watershed Area

**SECTION IX**

**APPENDIX B – REGION'S WATERSHEDS**



**Figure B-16: Thompsons Branch Watershed Area**

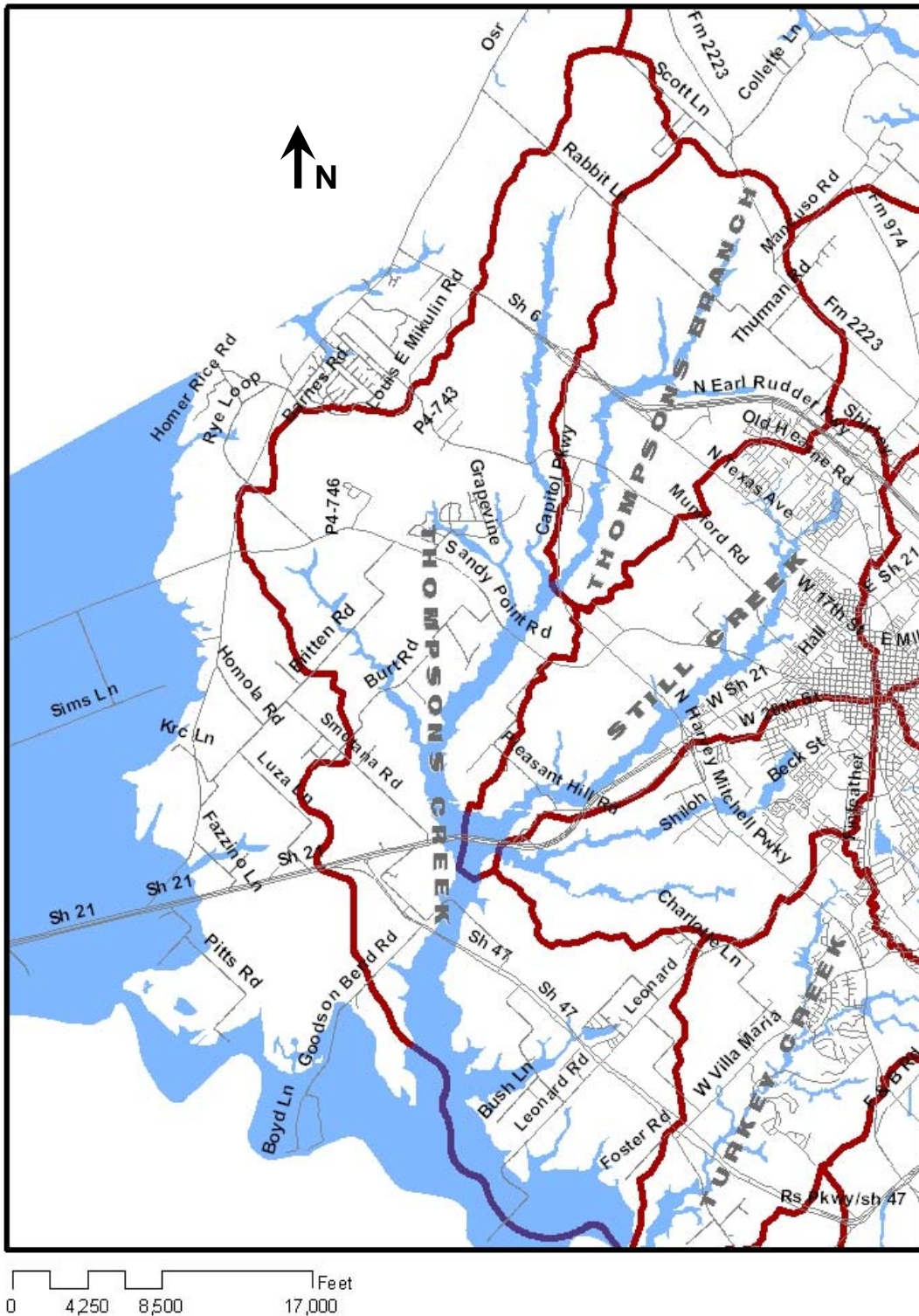

Figure B-17: Thompsons Creek Watershed Area

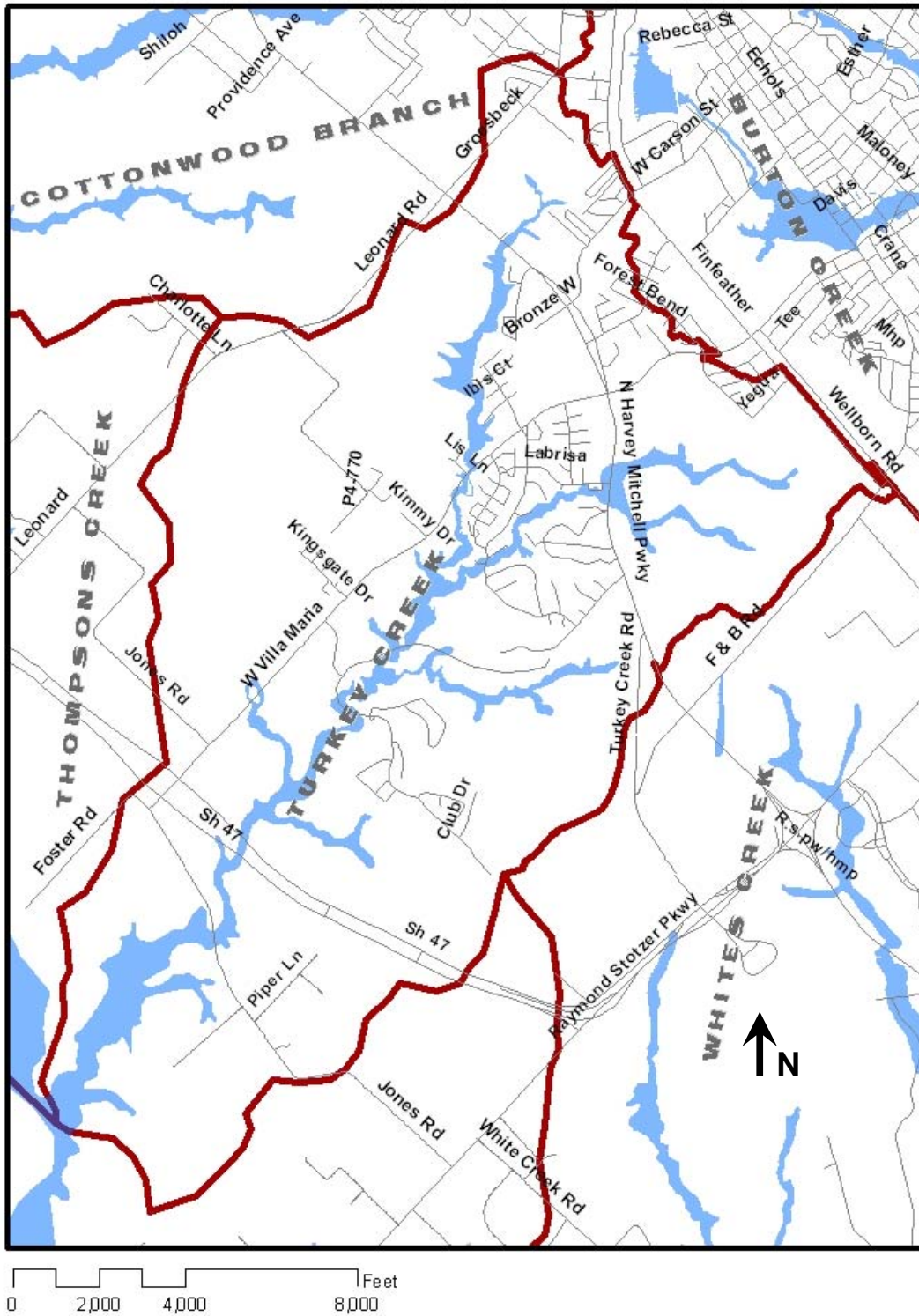

Figure B-18: Turkey Creek Watershed Area



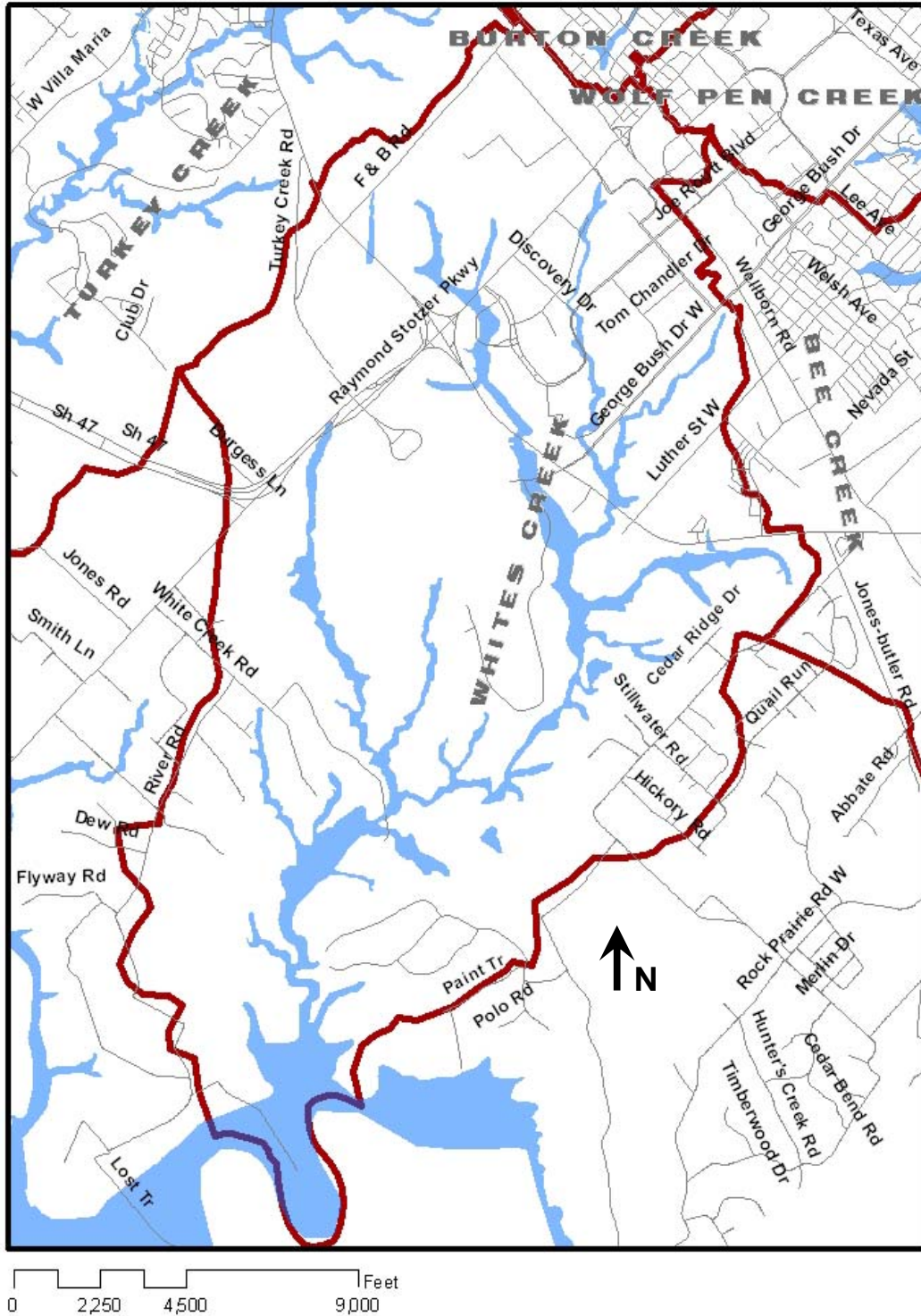

Figure B-19: Whites Creek Watershed Area

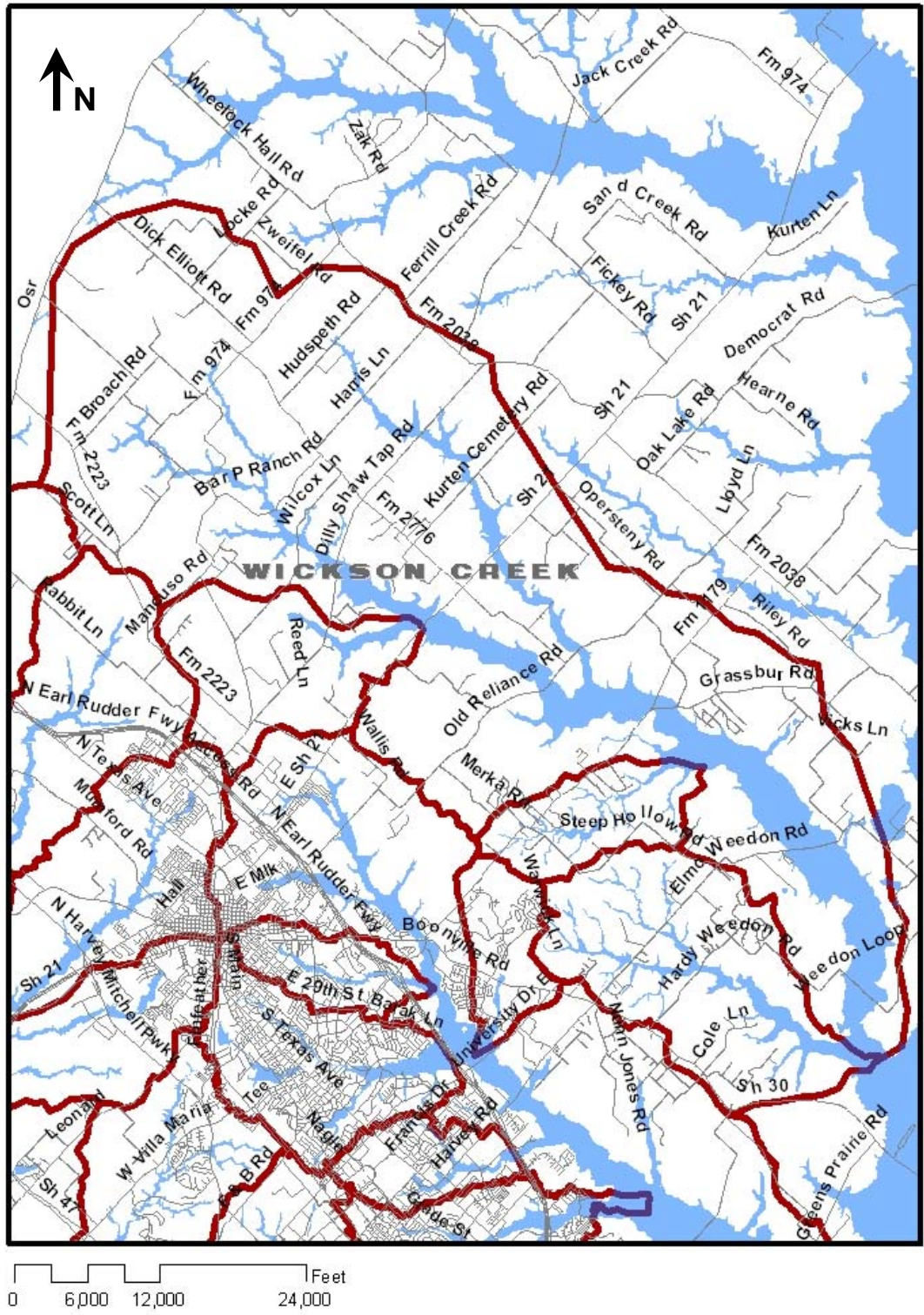

Figure B-20: Wickson Creek Watershed Area



# **Appendix C Computational Information**

## **Unified Stormwater Design Guidelines**

**City of College Station  
City of Bryan**

**AUGUST 2012**

# SECTION IX

## APPENDIX C – COMPUTATIONAL INFORMATION

### Hydrology Computational Information

This portion of Appendix C provides tables and figures in support of the methodologies stipulated in Section V of these Guidelines dealing with the application of hydrologic principles. It includes the following Tables and Figures:

- Table C-1: Equations for Calculating Rainfall Intensities
- Table C-2: Runoff Coefficients (C) by Land Use Type
- Table C-3: Runoff Coefficients (C) by Surface Type
- Table C-4: Runoff Velocities (v) for Determining Time of Concentration (  $t_c$  )
- Table C-5: Manning's Roughness Coefficients for Sheet Flow ( n )
- Table C-6: Depth-Duration-Interval Data (TP-40 and Hydro 35)
- Table C-7: Curve Numbers (SCS) and Percent Impervious Area

**Table C-1**  
**Equations for Calculating Rainfall Intensities**

Reference Section V, Paragraph B1-a, page 2 of 8)

<b>Storm Frequency</b>	<b>Intensity ( <math>i</math> ) (inches per hour)</b>
2-Year	$65/(t_c + 8.0)^{0.806}$
5-Year	$76/(t_c + 8.5)^{0.785}$
10-Year	$80/(t_c + 8.5)^{0.763}$
25-Year	$89/(t_c + 8.5)^{0.754}$
50-Year	$98/(t_c + 8.5)^{0.745}$
100-Year	$96/(t_c + 8.0)^{0.730}$

Source: TxDOT Hydraulic Manual, 1986.

# SECTION IX

## APPENDIX C – COMPUTATIONAL INFORMATION

**Table C-2**

**Runoff Coefficients ( c ) By Land Use Type**

Reference Section V, Paragraph B1-a, page 2 of 8.

Land Use Description	Slope	Range of Values	
		From	To
<b>Park and Open Space</b>	Flat (0 to 2%)	0.25	0.41
	Average (2 to 7%)	0.33	0.49
	Steep (>7%)	0.73	0.53
<b>Single Family Residential</b>			
<b>Lot size 5,000 to 7,000 sq. ft.</b>	Flat (0 to 2%)	0.50	0.69
	Average (2 to 7%)	0.54	0.74
	Steep (>7%)	0.56	0.76
<b>Lot size 7,000 to 10000 sq. ft.</b>	Flat (0 to 2%)	0.44	0.62
	Average (2 to 7%)	0.49	0.68
	Steep (>7%)	0.52	0.71
<b>Lot size 10,000 to 20,000 sq. ft.</b>	Flat (0 to 2%)	0.38	0.56
	Average (2 to 7%)	0.44	0.63
	Steep (>7%)	0.47	0.66
<b>Estate Lots ( &gt; 20,000 sq. ft.)</b>	Flat (0 to 2%)	0.32	0.48
	Average (2 to 7%)	0.38	0.56
	Steep (>7%)	0.42	0.60
<b>Multiple Family Residential</b>			
Low Density (3 stories or less)	All	0.65	0.74
Medium Density (6 stories or less)	All	0.68	0.76
High Density (more than 6 stories)	All	0.71	0.80
<b>Commercial</b>			
Limited & General Office Sites	All	0.75	0.84
Shopping Center Sites	All	0.79	0.88
Neighborhood Business Districts	All	0.79	0.88
Office Parks	All	0.80	0.88
Central Business District	All	0.87	0.96
<b>Industrial</b>			
Limited (service station, restaurant)	All	0.79	0.88
General (auto sales, rental storage)	All	0.79	0.88
Heavy (parking lots, warehousing)	All	0.87	0.96

Source: City of Temple Drainage Criteria Manual

# SECTION IX

## APPENDIX C – COMPUTATIONAL INFORMATION

**Table C-3**

**Runoff Coefficients ( c ) By Surface Type**

Reference Section V, Paragraph B1-a, page 2 of 8

Surface Description	Slope	Range of Values	
		From	To
<b>Undeveloped</b>			
Cultivated Land	Flat (0 to 2%)	0.31	0.47
	Average (2 to 7%)	0.35	0.51
	Steep (>7%)	0.39	0.54
Pasture / Unimproved	Flat (0 to 2%)	0.25	0.41
	Average (2 to 7%)	0.33	0.49
	Steep (>7%)	0.37	0.53
Wooded	Flat (0 to 2%)	0.22	0.39
	Average (2 to 7%)	0.31	0.47
	Steep (>7%)	0.35	0.52
Floodplains	Flat (0 to 2%)	0.40	0.60
<b>Developed Areas</b>			
Roof Areas	All	0.92	0.97
Asphaltic Areas	All	0.90	0.95
Concrete	All	0.92	0.97
Compacted Crushed Limestone Base	All	0.80	0.90
Grass Areas (lawns, parks, etc.)			
Poor Condition ( < 50% vegetative cover)	Flat (0 to 2%)	0.32	0.44
	Average (2 to 7%)	0.37	0.49
	Steep (>7%)	0.40	0.52
Fair Condition (50 to 75% vegetative cover)	Flat (0 to 2%)	0.25	0.37
	Average (2 to 7%)	0.33	0.45
	Steep (>7%)	0.37	0.49
Good Condition ( >75% vegetative cover)	Flat (0 to 2%)	0.21	0.32
	Average (2 to 7%)	0.29	0.42
	Steep (>7%)	0.34	0.47

Sources: Rossmiller, R.L. "The Rational Formula Revisited"; City of Austin Drainage Criteria Manual; City of Temple Drainage Criteria Manual. Revised by B/CS Drainage Design Guidelines Forum, March, 2005.

# SECTION IX

## APPENDIX C – COMPUTATIONAL INFORMATION

**Table C-4**  
**Runoff Velocities (v) for Determining Time of Concentration (t<sub>c</sub>)<sup>1</sup>**

Reference Section V, Paragraph B1-a, page 3 of 8.

Reach Description	Slope of Reach			
	0 to 3 %	4 to 7%	8 to 11%	>12%
	v *	v *	v*	v*
<b>Overland or Sheet Flow</b>				
Natural Woodlands	0 – 1.5	1.5 – 2.5	2.5 – 3.25	>3.25
Natural Grasslands	0 – 2.5	2.5 – 3.5	3.5 – 4.25	>4.25
Landscaped Areas	0 – 3.0	3.0 – 4.5	4.5 – 5.5	>5.5
Pavements	0 – 8.5	8.5 – 13.5	13.5 – 17.0	>17.0
<b>Concentrated Flow</b>				
Natural Channels	0 – 2.0	2.0 – 4.0	4.0 – 7.0	>7.0
Street or Gutter Flow	Use procedure in Section VI, Paragraphs A & B			
Storm Sewer	Use procedure in Section VI, Paragraph C			
Open Channels (designed)	Use procedure in Section VI, Paragraph D			

\*Note: "v " in feet per second

<sup>1</sup> From the "Hydraulic Design Manual" of the Texas Department of Transportation, 2002

**Table C-5**  
**Manning's Roughness Coefficients for Sheet Flow (n)**

Reference Section V, Paragraph B1-a, page 4 of 8

Description of Surface	Roughness Coefficient (n)
<b>Smooth surfaces</b> (concrete, asphalt, gravel or bare soil)	0.011
<b>Cultivated Soils</b>	
Fallow (no residue)	0.050
Residue Cover (less than 20%)	0.060
Residue Cover (greater than 20%)	0.170
<b>Grass</b>	
Short grass prairie	0.150
Dense grass prairie	0.240
Bermuda grass	0.410
<b>Range (natural)</b>	0.130
<b>Woods</b>	
Light underbrush	0.400
Dense underbrush	0.800

Source: After U.S. Department of Agriculture (1986).



# SECTION IX

## APPENDIX C – COMPUTATIONAL INFORMATION

**Table C-6**  
**Depth-Duration-Interval Data (TP-40 and Hydro 35)**

Reference Section V, Paragraph B2-b, page 5 of 8

Storm Duration	Rainfall Depth for Duration and Storm Recurrence Interval (inches)						
	2-year	5-year	10-year	25-year	50-year	100-year	USGS 500-year
5-min	0.53	0.60	0.66	0.75	0.82	0.89	-
15-min	1.15	1.33	1.46	1.66	1.82	1.98	3.0
30-min	1.68	2.00	2.24	2.59	2.87	3.14	3.6
60-min	2.20	2.68	3.02	3.52	3.91	4.30	5.8
2-hr	2.60	3.36	3.94	4.57	5.10	5.60	8.3
3-hr	2.86	3.70	4.41	5.14	5.65	6.30	9.0
6-hr	3.33	4.41	5.29	6.20	6.95	7.90	11.0
12-hr	3.80	5.25	6.28	7.42	8.45	9.50	12.5
24-hr	4.50	6.20	7.40	8.40	9.80	11.00	14.0

Source: Combination of Soil Conservation Service TP 40 and Hydro 35

**Table C-7**  
**Curve Numbers (SCS) and Percent Impervious Area<sup>1</sup>**

Reference Section V, Paragraph B2-b, page 5 of 8

Soil Type	Pasture	Wooded	Row Crops
A	49	36	67
B	69	60	78
C	79	76	85
D	84	79	89

For more complete information see TR-55, Table 2-2a

Category	Percent Impervious
<b>Land Uses</b>	
Low Density Residential	38
Medium Density Residential	52
High Density Residential	65
Business/Commercial	85
Industrial	72

<sup>1</sup> Values shall be calculated for watersheds in all cases.

#### **Hydraulic Computational Information**

This portion of Appendix C provides tables and figures in support of the methodologies stipulated in Section VI of these Guidelines dealing with the application of hydraulic design principles. It includes the following Tables and Figures:

- Table C-8: Equations for Sizing Inlets on Grade
- Table C-9: Coefficient of Loss,  $K_j$
- Table C-10: Manning's Roughness Coefficients,  $n$
- Table C-11: Maximum Design Velocities,  $V$
- Table C-12: Values of Entrance Loss Coefficients,  $K_e$

# SECTION IX

## APPENDIX C – COMPUTATIONAL INFORMATION

**Table C-8**  
**Equations for Sizing Inlets On Grade**

Reference Section VI, Paragraph B5-b, page 6 of 32

Ref. No.	Equation	Use
1	$L_x = K_c Q^{0.42} S^{0.3} \left( \frac{1}{n S_x} \right)^{0.6}$	Calculating length of curb inlet (without gutter depression) required for total interception of gutter flow.
2	$E = 1 - \left[ 1 - \frac{L_i}{L_T} \right]^{1.8}$	Calculating efficiency of curb inlet shorter than required length.
3	$E_o = \frac{Q_w}{Q} = 1 - \left[ 1 - \frac{W}{T} \right]^{2.67}$	Calculating $E_o$ , the ratio of the frontal flow to total gutter flow for a straight roadway cross slope; used in equation 4.
4	$S_e = S_x + \frac{a}{W} E_o$	Calculating $S_e$ to substitute for $S_x$ in Equation 1 to determine length of curb inlet (with gutter depression) for total interception of gutter flow.
NA	<p><b>Where symbols are as follows:</b></p> <ul style="list-style-type: none"> <li><math>E_o</math> = Ratio of frontal flow to total gutter flow</li> <li><math>Q_w</math> = Flow in width W, cfs</li> <li><math>Q</math> = Total gutter flow, cfs</li> <li><math>W</math> = Width of depressed gutter, feet</li> <li><math>T</math> = Total spread of water in gutter, feet</li> <li><math>K_c</math> = 0.6 (in English measure)</li> <li><math>L_x</math> = length of curb inlet required, feet</li> <li><math>S</math> = longitudinal slope, (ft/ft)</li> <li><math>n</math> = Manning's roughness coefficient</li> <li><math>S_x</math> = cross slope of road surface, (ft/ft)</li> <li><math>E</math> = Efficiency of inlet or percentage of interception</li> <li><math>L_i</math> = Curb-opening length, ft</li> <li><math>L_T</math> = Curb-opening length required for 100% interception, ft</li> <li><math>S_e</math> = equivalent cross slope, (ft/ft)</li> <li><math>a</math> = gutter depression depth, ft</li> </ul>	
<b>Note:</b>	The length of a <u>recessed</u> inlet is to be determined in the same manner as inlets having a depressed gutter section, because a depressed section is to be provided at the throat of the inlet but behind the curb line (Fig. C-1).	

# SECTION IX

## APPENDIX C – COMPUTATIONAL INFORMATION

**Table C-9**  
**Coefficient of Loss,  $K_j$ \***

Reference Section VI, Paragraph C3-b, page 9 of 32

<b>Design Condition</b>	<b><math>K_j</math>*</b>
Inlet on Main Line	0.50
Inlet on Main Line with Branch Lateral	0.25
Junction or Manhole on Main Line with 45 degree Branch Lateral	0.05
Junction or Manhole on Main Line with 90 degree Branch Lateral	0.25
Inlet or Manhole at Beginning of Line	1.25
Conduit on Curve for 90 degree	
Curve Radius = Diameter	0.05
Curve Radius = (2 to 8)	0.04
Curve Radius = (7 to 8)	0.25
** Where bends other than 90 Degree are used, then 90 Degree bend coefficient can be used with the following percentage factor applied:	60° Bend – 85% 45° Bend – 70% 22.5° Bend – 40%

\* From City of Austin Drainage Criteria Manual

# SECTION IX

## APPENDIX C – COMPUTATIONAL INFORMATION

**Table C-10**  
**Manning's Roughness Coefficients ( n )<sup>1</sup>**

Reference Section VI, Paragraph D2-b, page 12 of 32

Design Conditions	Coefficients	
	Min.	Max.
<b>Natural Stream Channels</b>		
Minor Streams With Fairly Regular Section, and:		
1. Some grass and weeds, little or no brush	0.030	0.035
2. Dense weeds, flow depth materially exceeds weed height	0.035	0.050
3. Some weeds, light brush on banks	0.035	0.050
4. Some weeds, heavy brush on banks	0.035	0.050
5. Some weeds, dense willows on banks	0.050	0.070
6. Trees in channels & branches submerged at high stage, increase all values above by:	0.010	0.020
Minor Streams With Irregular Section (pools, slight channel meander): use 1 to 5 above, and increase values by:	0.010	0.020
<b>Flood Plain (adjacent to natural streams)</b>		
Pasture: no brush, short grass	0.030	0.035
Pasture: no brush, tall grass	0.035	0.050
Heavy weeds, scattered brush	0.050	0.070
Wooded: Varies depending on undergrowth, height of foliage on trees, etc. The area of "n" = 0.10 and greater indicated extremely heavily wooded condition.	0.075	0.120
<b>Lined Channels</b>		
Metal corrugated	0.021	0.024
Neat concrete lined	0.012	0.018
Concrete	0.012	0.018
Concrete rubble	0.017	0.030
<b>Grass Covered Small Channels, Shallow Depth</b>		
No rank growth	0.035	0.045
Rank growth	0.040	0.050
<b>Unlined Channels</b>		
Earth, straight and uniform	0.017	0.025
Dredged	0.025	0.033
Winding and sluggish	0.022	0.030
Stony beds, weeds on bank	0.025	0.040
Earth bottom, rubble sides	0.028	0.035

<sup>1</sup> From "Hydraulic Design Manual" of Texas Department of Transportation, 2002

# SECTION IX

## APPENDIX C – COMPUTATIONAL INFORMATION

**Table C-11**  
**Maximum Design Velocities ( V ) <sup>1</sup>**

Reference: Section VI, Paragraph D3-a, page 13 of 32

Surface Treatment	Max. Design Velocity
Grass: seeded with erosion matt	4.5 ft./sec.
Grass: established sod	6.0 ft./sec.
Rubble: placed rock or concrete	10.0 ft./sec.
Impermeable: (concrete, Gunitite, etc.)	15.0 ft./sec.
Gutter Flow (Sec.6, A.2.a)	10.0 ft./sec.
Channel (25-year)	Min. 2.5 ft./sec. - Max (below)
Conduit (10-year)	Min. 2.5 ft./sec. – Max. 15.0 ft./sec.
*Note: Velocities in excess of 12 feet per second shall require additional methods such as baffles, stilling basins, and/or drop structures to reduce velocities to levels stipulated.	

<sup>1</sup>From “Erosion and Sediment Control Guidelines for Developing Areas in Texas” by the US Soil Conservation Service.

**Table C-12**  
**Values of Entrance Loss Coefficients, K<sub>e</sub> <sup>1</sup>**

Reference Section VI, Paragraph F5-d, page 28 of 32

Type of Structure and Entrance Design	Value of K <sub>e</sub>
<b>Box, Reinforced Concrete (Submerged Entrance)</b>	
Parallel Wing walls	0.5
Flared Wing walls	0.4
<b>Box, Reinforced Concrete (Free Surface Flow)</b>	
Parallel Wing walls	0.5
Flared Wing walls	0.15
<b>Pipe, Concrete</b>	
Projecting from fill, socket end	0.2
Projecting from fill, square cut end	0.5
With headwall or headwall and wing walls	
Socket end of pipe	0.2
Square cut end	0.5
End-section conforming to fill slope	0.5
<b>Pipe or Pipe-Arch, Corrugated Metal</b>	
Projecting from fill (no headwall)	0.9
Headwall or headwall & wing walls (square edge)	0.5
End-section conforming to fill slope	0.5

<sup>1</sup>From City of Austin Drainage Criteria Manual

# SECTION IX

## APPENDIX C – COMPUTATIONAL INFORMATION

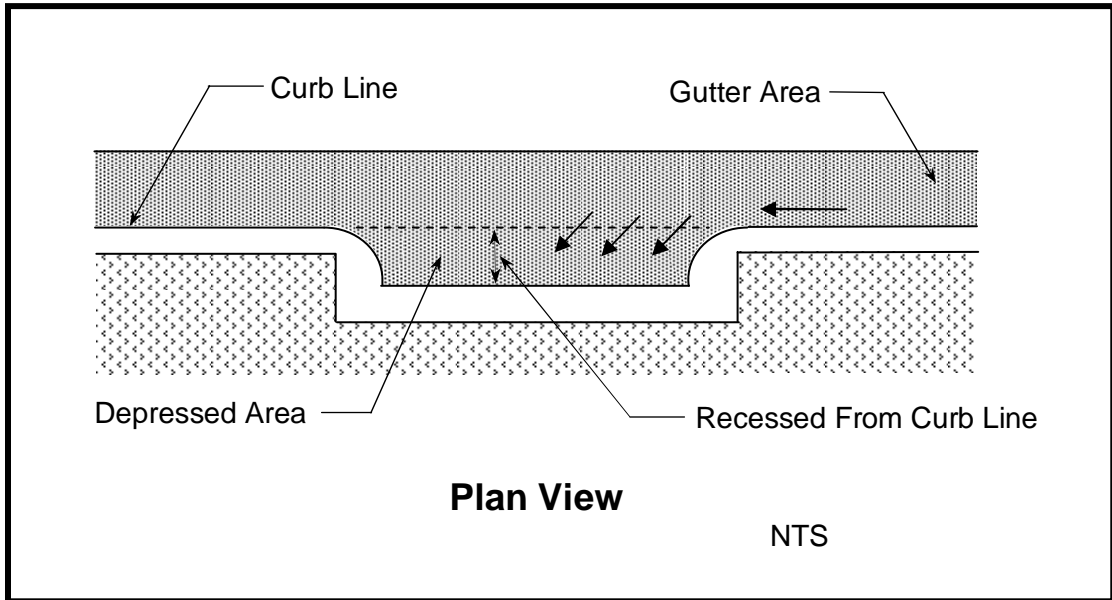

**Figure C-1: Recessed Curb Inlet Diagram**

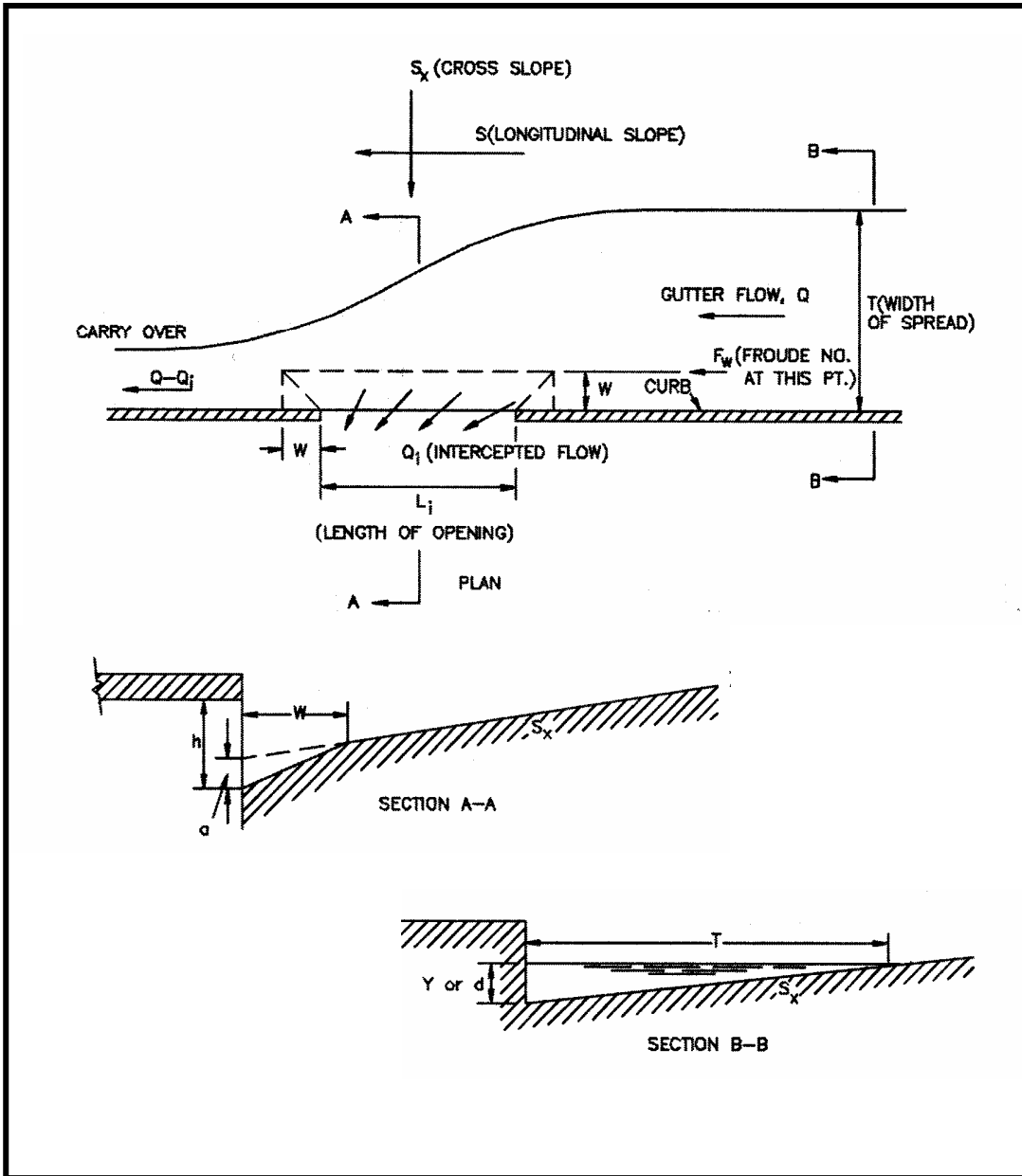
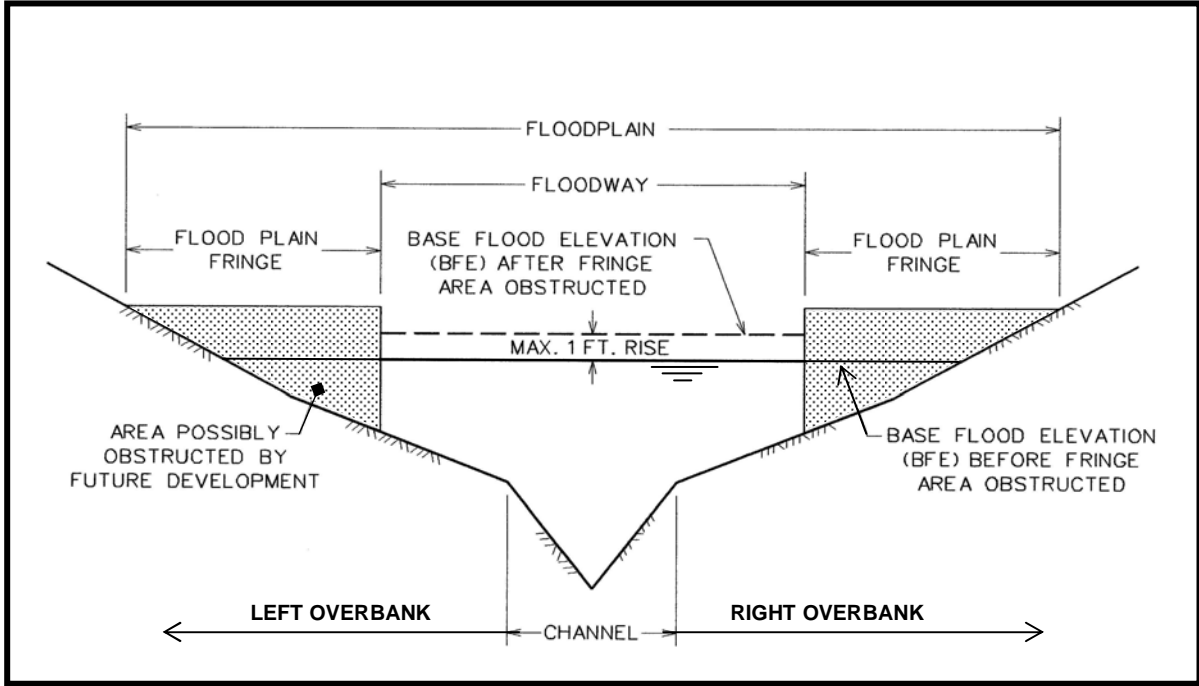

Figure C-2: Non-Recessed Curb Inlet Diagram



# SECTION IX

## APPENDIX C – COMPUTATIONAL INFORMATION



**Figure C-3: Floodplain – Floodway Diagram**

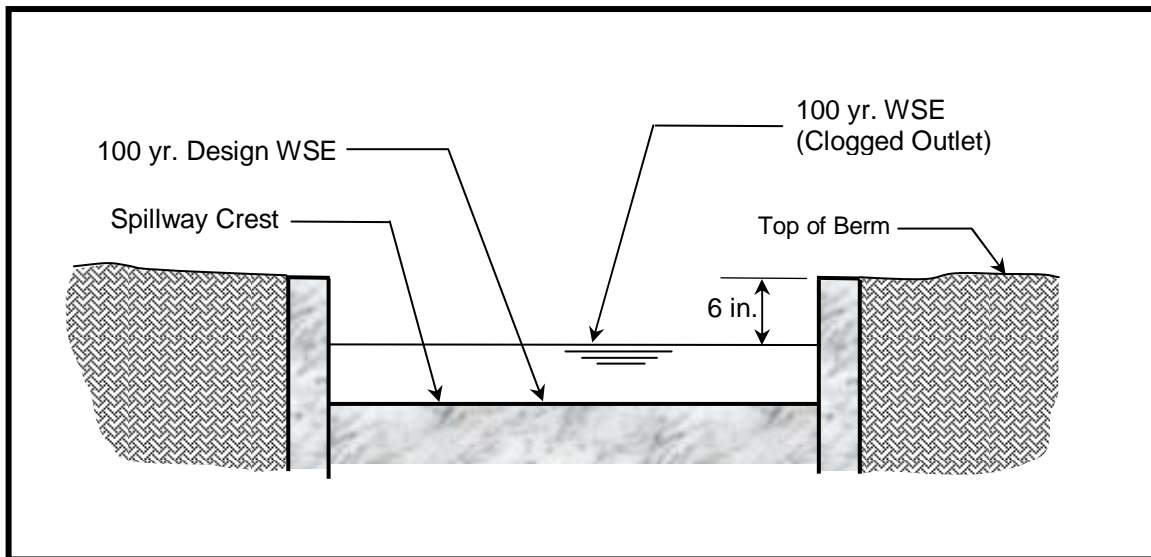

**Figure C-4: Diagram of Detention Spillway Section**

## SECTION IX

### APPENDIX C – COMPUTATIONAL INFORMATION

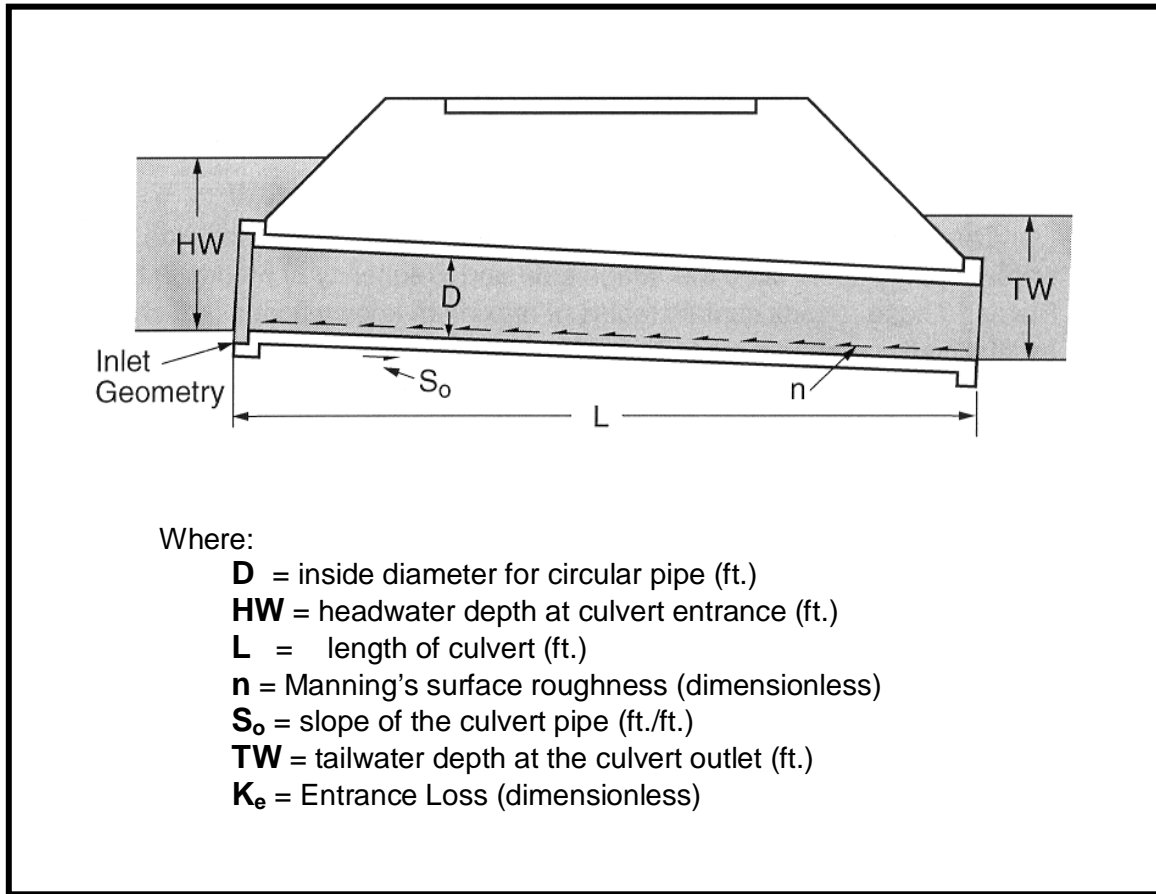

**Figure C-5: Factors Influencing Culvert Discharge**

# **Appendix D Technical Design Summary**

## **Unified Stormwater Design Guidelines**

**City of College Station  
City of Bryan**

**AUGUST 2012**

# SECTION IX

## APPENDIX D – TECHNICAL DESIGN SUMMARY

The Cities of Bryan and College Station both require storm drainage design to follow these Unified Stormwater Design Guidelines. Paragraph C2 of Section III (Administration) requires submittal of a drainage report in support of the drainage plan (stormwater management plan) proposed in connection with land development projects, both site projects and subdivisions. That report may be submitted as a traditional prose report, complete with applicable maps, graphs, tables and drawings, or it may take the form of a “Technical Design Summary”. The format and content for such a summary report shall be in substantial conformance with the description in this Appendix to those Guidelines. In either format the report must answer the questions (affirmative or negative) and provide, at minimum, the information prescribed in the “Technical Design Summary” in this Appendix.

The Stormwater Management Technical Design Summary Report shall include several parts as listed below. The information called for in each part must be provided as applicable. In addition to the requirements for the Executive Summary, this Appendix includes several pages detailing the requirements for a Technical Design Summary Report as forms to be completed. These are provided so that they may be copied and completed or scanned and digitized. In addition, electronic versions of the report forms may be obtained from the City. Requirements for the means (medium) of submittal are the same as for a conventional report as detailed in Section III of these Guidelines.

**Note:** Part 1 – Executive Summary must accompany any drainage report required to be provided in connection with any land development project, regardless of the format chosen for said report.

**Note:** Parts 2 through 6 are to be provided via the forms provided in this Appendix. Brief statements should be included in the forms as requested, but additional information should be attached as necessary.

### **Part 1 – Executive Summary Report**

### **Part 2 – Project Administration**

### **Part 3 – Project Characteristics**

### **Part 4 – Drainage Concept and Design Parameters**

### **Part 5 – Plans and Specifications**

### **Part 6 – Conclusions and Attestation**

## STORMWATER MANAGEMENT TECHNICAL DESIGN SUMMARY REPORT

### **Part 1 – Executive Summary**

This is to be a brief prose report that must address each of the seven areas listed below. Ideally it will include one or more paragraphs about each item.

1. Name, address, and contact information of the engineer submitting the report, and of the land owner and developer (or applicant if not the owner or developer). The date of submittal should also be included.
2. Identification of the size and general nature of the proposed project, including any proposed project phases. This paragraph should also include reference to

## **SECTION IX**

### **APPENDIX D – TECHNICAL DESIGN SUMMARY**

applications that are in process with either City: plat(s), site plans, zoning requests, or clearing/grading permits, as well as reference to any application numbers or codes assigned by the City to such request.

3. The location of the project should be described. This should identify the Named Regulatory Watershed(s) in which it is located, how the entire project area is situated therein, whether the property straddles a watershed or basin divide, the approximate acreage in each basin, and whether its position in the Watershed dictates use of detention design. The approximate proportion of the property in the city limits and within the ETJ is to be identified, including whether the property straddles city jurisdictional lines. If any portion of the property is in floodplains as described in Flood Insurance Rate Maps published by FEMA that should be disclosed.
4. The hydrologic characteristics of the property are to be described in broad terms: existing land cover; how and where stormwater drains to and from neighboring properties; ponds or wetland areas that tend to detain or store stormwater; existing creeks, channels, and swales crossing or serving the property; all existing drainage easements (or ROW) on the property, or on neighboring properties if they service runoff to or from the property.
5. The general plan for managing stormwater in the entire project area must be outlined to include the approximate size, and extent of use, of any of the following features: storm drains coupled with streets; detention / retention facilities; buried conveyance conduit independent of streets; swales or channels; bridges or culverts; outfalls to principal watercourses or their tributaries; and treatment(s) of existing watercourses. Also, any plans for reclaiming land within floodplain areas must be outlined.
6. Coordination and permitting of stormwater matters must be addressed. This is to include any specialized coordination that has occurred or is planned with other entities (local, state, or federal). This may include agencies such as Brazos County government, the Brazos River Authority, the Texas A&M University System, the Texas Department of Transportation, the Texas Commission for Environmental Quality, the US Army Corps of Engineers, the US Environmental Protection Agency, et al. Mention must be made of any permits, agreements, or understandings that pertain to the project.
7. Reference is to be made to the full drainage report (or the Technical Design Summary Report) which the executive summary represents. The principal elements of the main report (and its length), including any maps, drawings or construction documents, should be itemized. An example statement might be:

“One \_\_\_\_-page drainage report dated \_\_\_\_\_, one set of construction drawings (\_\_\_\_sheets) dated \_\_\_\_\_, and a \_\_\_\_-page specifications document dated \_\_\_\_\_ comprise the drainage report for this project.”



# SECTION IX

## APPENDIX D – TECHNICAL DESIGN SUMMARY

<b>Part 2 – Project Administration</b>		Continued (page 2.2)
<b>Project Identification (continued)</b>		
Roadways abutting or within <b>Project Area</b> or subject property:	Abutting tracts, platted land, or built developments:	
Named Regulatory Watercourse(s) & Watershed(s):	Tributary Basin(s):	
<b>Plat Information For Project or Subject Property (or Phase)</b>		
Preliminary Plat File #: _____	Final Plat File #: _____ Date: _____	
Name:	Status and Vol/Pg:	
If two plats, second name:	File #: _____	
Status:	Date: _____	
<b>Zoning Information For Project or Subject Property (or Phase)</b>		
Zoning Type: _____	Existing or Proposed? _____	Case Code: _____
Case Date _____	Status: _____	
Zoning Type: _____	Existing or Proposed? _____	Case Code: _____
Case Date _____	Status: _____	
<b>Stormwater Management Planning For Project or Subject Property (or Phase)</b>		
Planning Conference(s) & Date(s):	Participants:	
Preliminary Report Required? _____ Submittal Date _____ Review Date _____		
Review Comments Addressed? Yes ____ No ____ In Writing? _____ When? _____		
<b>Compliance With Preliminary Drainage Report.</b> Briefly describe (or attach documentation explaining) any deviation(s) from provisions of Preliminary Drainage Report, if any.		

# SECTION IX

## APPENDIX D – TECHNICAL DESIGN SUMMARY

<b>Part 2 – Project Administration</b>			Continued (page 2.3)	
<b>Coordination For Project or Subject Property (or Phase)</b>				
<b>Note:</b> For any Coordination of stormwater matters indicated below, attach documentation describing and substantiating any agreements, understandings, contracts, or approvals.				
Coordination With Other Departments of <b>Jurisdiction City</b> (Bryan or College Station)	Dept.	Contact:	Date:	Subject:
Coordination With <b>Non-jurisdiction City</b> Needed? Yes ____ No ____	Summarize need(s) & actions taken (include contacts & dates):			
Coordination with Brazos County Needed? Yes ____ No ____	Summarize need(s) & actions taken (include contacts & dates):			
Coordination with TxDOT Needed? Yes ____ No ____	Summarize need(s) & actions taken (include contacts & dates):			
Coordination with TAMUS Needed? Yes ____ No ____	Summarize need(s) & actions taken (include contacts & dates):			
<b>Permits For Project or Subject Property (or Phase)</b>				
As to stormwater management, are permits required for the proposed work from any of the entities listed below? If so, summarize status of efforts toward that objective in spaces below.				
<b>Entity</b>	<b>Permitted or Approved ?</b>	<b>Status of Actions</b> (include dates)		
US Army Corps of Engineers No ____ Yes ____				
US Environmental Protection Agency No ____ Yes ____				
Texas Commission on Environmental Quality No ____ Yes ____				
Brazos River Authority No ____ Yes ____				



# SECTION IX

## APPENDIX D – TECHNICAL DESIGN SUMMARY

<b>Part 3 – Property Characteristics</b>		Start (Page 3.1)
<b>Nature and Scope of Proposed Work</b>		
<b>Existing:</b> Land proposed for development currently used, including extent of impervious cover?		
<b>Site Development Project</b> (select all applicable)	<input type="checkbox"/> <u>Redevelopment</u> of one <u>platted</u> lot, or two or more adjoining <u>platted</u> lots.	
	<input type="checkbox"/> Building on a single <u>platted</u> lot of undeveloped land.	
	<input type="checkbox"/> Building on two or more <u>platted</u> adjoining lots of undeveloped land.	
	<input type="checkbox"/> Building on a single lot, or adjoining lots, where <u>proposed</u> plat will not form a new street (but may include ROW dedication to existing streets).	
	<input type="checkbox"/> Other (explain):	
<b>Subdivision Development Project</b>	<input type="checkbox"/> Construction of streets and utilities to serve one or more <u>platted</u> lots.	
	<input type="checkbox"/> Construction of streets and utilities to serve one or more proposed lots on lands represented by <u>pending plats</u> .	
<b>Describe Nature and Size of Proposed Project</b>	<u>Site projects:</u> building use(s), approximate floor space, impervious cover ratio. <u>Subdivisions:</u> number of lots by general type of use, linear feet of streets and drainage easements or ROW.	
Is any work planned on land that is <u>not platted</u> or on land for which platting is <u>not pending</u> ? <input type="checkbox"/> No <input type="checkbox"/> Yes		If yes, explain:
<b>FEMA Floodplains</b>		
Is any part of subject property abutting a Named Regulatory Watercourse (Section II, Paragraph B1) or a tributary thereof?		No <input type="checkbox"/> Yes <input type="checkbox"/>
Is any part of subject property in floodplain area of a FEMA-regulated watercourse?		No <input type="checkbox"/> Yes <input type="checkbox"/> Rate Map _____
Encroachment(s) into Floodplain areas planned?  No <input type="checkbox"/> Yes <input type="checkbox"/>	Encroachment purpose(s): <input type="checkbox"/> Building site(s) <input type="checkbox"/> Road crossing(s) <input type="checkbox"/> Utility crossing(s) <input type="checkbox"/> Other (explain):	
If floodplain areas not shown on Rate Maps, has work been done toward amending the FEMA-approved Flood Study to define allowable encroachments in proposed areas? Explain.		

# SECTION IX

## APPENDIX D – TECHNICAL DESIGN SUMMARY

<b>Part 3 – Property Characteristics</b>		Continued (Page 3.2)
<b>Hydrologic Attributes of Subject Property (or Phase)</b>		
Has an earlier hydrologic analysis been done for larger area including subject property?		
Yes _____	Reference the study (& date) here, and attach copy if not already in City files.	
No _____	Is the stormwater management plan for the property in substantial conformance with the earlier study? Yes _____ No _____ If not, explain how it differs.	
No _____	If subject property <b>is not</b> part of multi-phase project, describe stormwater management plan for the property in Part 4.	
No _____	If property <b>is</b> part of multi-phase project, provide overview of stormwater management plan for <b>Project Area</b> here. In Part 4 describe how plan for subject property will comply therewith.	
Do existing topographic features on subject property store or detain runoff? _____ No _____ Yes Describe them (include approximate size, volume, outfall, model, etc).		
Any known drainage or flooding problems in areas near subject property? _____ No _____ Yes Identify:		
Based on location of study property in a watershed, is <b>Type 1 Detention</b> (flood control) needed? (see Table B-1 in Appendix B) _____ Detention is required. _____ Need must be evaluated. _____ Detention not required.		
If the need for <b>Type 1 Detention</b> must be evaluated:	What decision has been reached? By whom?	
	How was determination made?	

# SECTION IX

## APPENDIX D – TECHNICAL DESIGN SUMMARY

<b>Part 3 – Property Characteristics</b>		Continued (Page 3.3)
<b>Hydrologic Attributes of Subject Property (or Phase) (continued)</b>		
Does subject property straddle a Watershed or Basin divide? ____ No ____ Yes If yes, describe splits below. In Part 4 describe design concept for handling this.		
<b>Watershed or Basin</b>	<b>Larger acreage</b>	<b>Lesser acreage</b>
<b>Above-Project Areas</b> (Section II, Paragraph B3-a)		
Does Project Area (project or phase) receive runoff from upland areas? ____ No ____ Yes Size(s) of area(s) in acres: 1) _____ 2) _____ 3) _____ 4) _____		
<u>Flow Characteristics (each instance)</u> (overland sheet, shallow concentrated, recognizable concentrated section(s), small creek (non-regulatory), regulatory Watercourse or tributary);		
<u>Flow determination:</u> Outline hydrologic methods and assumptions:		
Does storm runoff drain from public easements or ROW onto or across subject property? ____ No ____ Yes If yes, describe facilities in easement or ROW:		
Are changes in runoff characteristics subject to change in future? Explain		
<b>Conveyance Pathways</b> (Section II, Paragraph C2)		
Must runoff from study property drain across lower properties before reaching a Regulatory Watercourse or tributary? ____ No ____ Yes		
Describe length and characteristics of each conveyance pathway(s). Include ownership of property(ies).		

# SECTION IX

## APPENDIX D – TECHNICAL DESIGN SUMMARY

<b>Part 3 – Property Characteristics</b>		Continued (Page 3.4)
<b>Hydrologic Attributes of Subject Property (or Phase) (continued)</b>		
<b>Conveyance Pathways (continued)</b>		
	Do drainage easements exist for any part of pathway(s)? <input type="checkbox"/> No <input type="checkbox"/> Yes	If yes, for what part of length? _____% Created by? ____ plat, or _____ instrument. If instrument(s), describe their provisions.
<b>Pathway Areas</b>	Where runoff must cross lower properties, describe characteristics of abutting lower property(ies). (Existing watercourses? Easement or Consent acquired?)	
<b>Nearby Drainage Facilities</b>	Describe any built or improved drainage facilities existing near the property (culverts, bridges, lined channels, buried conduit, swales, detention ponds, etc).	
	Do any of these have hydrologic or hydraulic influence on proposed stormwater design? <input type="checkbox"/> No <input type="checkbox"/> Yes If yes, explain:	

# SECTION IX

## APPENDIX D – TECHNICAL DESIGN SUMMARY

<b>Part 4 – Drainage Concept and Design Parameters</b>		Start (Page 4.1)
<b>Stormwater Management Concept</b>		
<b>Discharge(s) <u>From</u> Upland Area(s)</b>		
<p>If runoff is to be received from upland areas, what design drainage features will be used to accommodate it and insure it is not blocked by future development? Describe for each area, flow section, or discharge point.</p>		
<b>Discharge(s) <u>To</u> Lower Property(ies)</b> (Section II, Paragraph E1)		
<p>Does project include drainage features (existing or future) proposed to become public via platting? <input type="checkbox"/> No <input type="checkbox"/> Yes      Separate Instrument? <input type="checkbox"/> No <input type="checkbox"/> Yes</p>		
<p>Per Guidelines reference above, how will runoff be discharged to neighboring property(ies)?</p>	<p><input type="checkbox"/> Establishing Easements (Scenario 1)  <input type="checkbox"/> Pre-development Release (Scenario 2)  <input type="checkbox"/> Combination of the two Scenarios</p>	
<p><u>Scenario 1</u>: If easements are proposed, describe where needed, and provide status of actions on each. (Attached Exhibit # _____)</p>		
<p><u>Scenario 2</u>: Provide general description of how release(s) will be managed to pre-development conditions (detention, sheet flow, partially concentrated, etc.). (Attached Exhibit # _____)</p>		
<p><u>Combination</u>: If combination is proposed, explain how discharge will differ from pre-development conditions at the property line for each area (or point) of release.</p>		
<p>If <u>Scenario 2</u>, or <u>Combination</u> are to be used, has proposed design been coordinated with owner(s) of receiving property(ies)? <input type="checkbox"/> No <input type="checkbox"/> Yes Explain and provide documentation.</p>		

# SECTION IX

## APPENDIX D – TECHNICAL DESIGN SUMMARY

<b>Part 4 – Drainage Concept and Design Parameters</b>		Continued (Page 4.2)
<b>Stormwater Management Concept (continued)</b>		
<b>Within <u>Project Area</u> Of Multi-Phase Project</b>		
Will project result in shifting runoff between Basins or between Watersheds?  _____ No _____ Yes	Identify gaining Basins or Watersheds and acres shifting:  What design and mitigation is used to compensate for increased runoff from gaining basin or watershed?	
How will runoff from <b>Project Area</b> be mitigated to pre-development conditions? Select any or all of 1, 2, and/or 3, and explain below.	1. _____ With facility(ies) involving other development projects. 2. _____ Establishing features to serve overall Project Area. 3. _____ On phase (or site) project basis within Project Area.	
1. <u>Shared facility</u> (type & location of facility; design drainage area served; relationship to size of Project Area): (Attached Exhibit # _____)		
2. <u>For Overall Project Area</u> (type & location of facilities): (Attached Exhibit # _____)		
3. <u>By phase (or site) project</u> : Describe planned mitigation measures for phases (or sites) in subsequent questions of this Part.		
Are Special Designs Planned? _____ No _____ Yes	Are aquatic ecosystems proposed? _____ No _____ Yes In which phase(s) or project(s)?	
	Are other Best Management Practices for reducing stormwater pollutants proposed? _____ No _____ Yes Summarize type of BMP and extent of use:	
	If design of any runoff-handling facilities deviate from provisions of B-CS Technical Specifications, check type facility(ies) and explain in later questions. _____ Detention elements _____ Conduit elements _____ Channel features _____ Swales _____ Ditches _____ Inlets _____ Valley gutters _____ Outfalls _____ Culvert features _____ Bridges _____ Other	

# SECTION IX

## APPENDIX D – TECHNICAL DESIGN SUMMARY

<b>Part 4 – Drainage Concept and Design Parameters</b>		Continued (Page 4.3)	
<b>Stormwater Management Concept (continued)</b>			
<b>Within Project Area Of Multi-Phase Project (continued)</b>			
Will Project Area include bridge(s) or culvert(s)? ____ No ____ Yes Identify type and general size and In which phase(s).			
If detention/retention serves (will serve) overall Project Area, describe how it relates to subject phase or site project (physical location, conveyance pathway(s), construction sequence):			
<b>Within Or Serving Subject Property (Phase, or Site)</b>			
If property part of larger Project Area, is design in substantial conformance with earlier analysis and report for larger area? ____ Yes ____ No, then summarize the difference(s):			
Identify whether each of the types of drainage features listed below are included, extent of use, and general characteristics.			
Are roadside ditches used? ____ No ____ Yes	Typical shape?		Surfaces?
	Steepest side slopes:	Usual front slopes:	Usual back slopes:
	Flow line slopes: least _____ typical _____ greatest _____		Typical distance from travelway: (Attached Exhibit # _____)
	Are longitudinal culvert ends in compliance with B-CS Standard Specifications? ____ Yes ____ No, then explain:		
Are streets with curb and gutter used? ____ No ____ Yes	At intersections or otherwise, do valley gutters cross arterial or collector streets? ____ No ____ Yes If yes explain:		
	Are valley gutters proposed to cross any street away from an intersection? ____ No ____ Yes Explain: (number of locations?)		

# SECTION IX

## APPENDIX D – TECHNICAL DESIGN SUMMARY

<b>Part 4 – Drainage Concept and Design Parameters</b>		Continued (Page 4.4)
<b>Stormwater Management Concept (continued)</b>		
<b>Within Or Serving Subject Property (Phase, or Site) (continued)</b>		
Are streets with curb and gutter used? (continued)	Gutter line slopes: Least _____ Usual _____ Greatest _____	
	Are inlets <u>recessed</u> on arterial and collector streets? ____ Yes ____ No If “no”, identify where and why.	
	Will inlets capture 10-year design stormflow to prevent flooding of intersections (arterial with arterial or collector)? ____ Yes ____ No If no, explain where and why not.	
	Will inlet size and placement prevent exceeding allowable water spread for 10-year design storm throughout site (or phase)? ____ Yes ____ No If no, explain.	
	<u>Sag curves</u> : Are inlets placed at low points? ____ Yes ____ No Are inlets and conduit sized to prevent 100-year stormflow from ponding at greater than 24 inches? ____ Yes ____ No Explain “no” answers.	
	Will 100-yr stormflow be contained in combination of ROW and buried conduit on whole length of all streets? ____ Yes ____ No If no, describe where and why.	
	Do designs for curb, gutter, and inlets comply with B-CS Technical Specifications? ____ Yes ____ No If not, describe difference(s) and attach justification.	
Is storm drain system used? Yes ____ No ____	Are any 12-inch laterals used? ____ No ____ Yes Identify length(s) and where used.	
	Pipe runs between system access points (feet):	Typical _____ Longest _____
	Are junction boxes used at each bend? ____ Yes ____ No If not, explain where and why.	
	Are downstream soffits at or below upstream soffits? Yes ____ No ____ If not, explain where and why:	Least amount that hydraulic grade line is below gutter line (system-wide):



# SECTION IX

## APPENDIX D – TECHNICAL DESIGN SUMMARY

<b>Part 4 – Drainage Concept and Design Parameters</b>		Continued (Page 4.5)
<b>Stormwater Management Concept (continued)</b>		
<b>Within Or Serving Subject Property (Phase, or Site) (continued)</b>		
Storm drain system (continued) (on separate sheet provide same info. for more instances)	Outfall(s)	Describe watercourse(s), or system(s) receiving system discharge(s) below (include design discharge velocity, and angle between converging flow lines).
		1) Watercourse (or system), velocity, and angle?
		2) Watercourse (or system), velocity, and angle?
		3) Watercourse (or system), velocity, and angle?
		For each outfall above, what measures are taken to prevent erosion or scour of receiving and all facilities at juncture? 1) 2) 3)
Are swales used to drain streets? No _____ Yes _____	Are swale(s) situated along property lines between properties? _____ No _____ Yes Number of instances: _____ For each instance answer the following questions.	
	Surface treatments (including low-flow flumes if any):	
	Flow line slopes (minimum and maximum):	
	Outfall characteristics for each (velocity, convergent angle, & end treatment).	
	Will 100-year design storm runoff be contained within easement(s) or platted drainage ROW in all instances? _____ Yes _____ No If "no" explain:	

# SECTION IX

## APPENDIX D – TECHNICAL DESIGN SUMMARY

<b>Part 4 – Drainage Concept and Design Parameters</b>		Continued (Page 4.6)
<b>Stormwater Management Concept (continued)</b>		
<b>Within Or Serving Subject Property (Phase, or Site) (continued)</b>		
Roadside Ditches	Are roadside ditches used? ____ No ____ Yes If so, provide the following: Is 25-year flow contained with 6 inches of freeboard throughout ? ____ Yes ____ No Are top of banks separated from road shoulders 2 feet or more? ____ Yes ____ No Are all ditch sections trapezoidal and at least 1.5 feet deep? ____ Yes ____ No For any “no” answers provide location(s) and explain:	
	For any “no” answers provide location(s) and explain:	
Are swale/conduit combinations used in lieu of open channels? ____ No ____ Yes (on separate sheet provide same information for any additional instances)	If conduit is beneath a swale, provide the following information (each instance). <b>Instance 1</b> Describe general location, approximate length:	
	Is 100-year design flow contained in conduit/swale combination? ____ Yes ____ No If “no” explain:	
	Space for 100-year storm flow? ROW ____ Easement ____ Width ____	
	<u>Swale</u> Surface type, minimum and maximum slopes:	<u>Conduit</u> Type and size, minimum and maximum slopes, design storm:
	<u>Inlets</u> Describe how conduit is loaded (from streets/storm drains, inlets by type):	
	<u>Access</u> Describe how maintenance access is provided (to swale, into conduit):	
	<b>Instance 2</b> Describe general location, approximate length:	
	Is 100-year design flow contained in conduit/swale combination? ____ Yes ____ No If “no” explain:	
	Space for 100-year storm flow? ROW ____ Easement ____ Width ____	
	<u>Swale</u> Surface type, minimum and maximum slopes:	<u>Conduit</u> Type and size, minimum and maximum slopes, design storm:
	<u>Inlets</u> Describe how conduit is loaded (from streets/storm drains, inlets by type):	
	<u>Access</u> Describe how maintenance access is provided (to swale, into conduit):	

# SECTION IX

## APPENDIX D – TECHNICAL DESIGN SUMMARY

<b>Part 4 – Drainage Concept and Design Parameters</b>		Continued (Page 4.7)
<b>Stormwater Management Concept (continued)</b>		
<b>Within Or Serving Subject Property (Phase, or Site) (continued)</b>		
Will swales without buried conduit receive runoff from public ROW or easements?	Yes <input type="checkbox"/> No <input type="checkbox"/> Explain	If "yes" provide the following information for each instance: <b>Instance 1</b> Describe general location, approximate length, surfacing:
		Is 100-year design flow contained in swale? <input type="checkbox"/> Yes <input type="checkbox"/> No <input type="checkbox"/> Is swale wholly within drainage ROW? <input type="checkbox"/> Yes <input type="checkbox"/> No <input type="checkbox"/> Explain "no" answers:
		<u>Access</u> Describe how maintenance access is provide:
		<b>Instance 2</b> Describe general location, approximate length, surfacing:
		Is 100-year design flow contained in swale? <input type="checkbox"/> Yes <input type="checkbox"/> No <input type="checkbox"/> Is swale wholly within drainage ROW? <input type="checkbox"/> Yes <input type="checkbox"/> No <input type="checkbox"/> Explain "no" answers:
		<u>Access</u> Describe how maintenance access is provided:
		<b>Instance 3, 4, etc.</b> If swales are used in more than two instances, attach sheet providing all above information for each instance.
Channel improvements proposed?	Yes <input type="checkbox"/> No <input type="checkbox"/> Explain	<b>"New" channels:</b> Will any area(s) of concentrated flow be channelized (deepened, widened, or straightened) or otherwise altered? <input type="checkbox"/> No <input type="checkbox"/> Yes <input type="checkbox"/> If only slightly shaped, see "Swales" in this Part. If creating side banks, provide information below.
		Will design replicate natural channel? <input type="checkbox"/> Yes <input type="checkbox"/> No <input type="checkbox"/> If "no", for each instance describe section shape & area, flow line slope (min. & max.), surfaces, and 100-year design flow, and amount of freeboard: Instance 1:  Instance 2:  Instance 3:

# SECTION IX

## APPENDIX D – TECHNICAL DESIGN SUMMARY

<b>Part 4 – Drainage Concept and Design Parameters</b>		Continued (Page 4.8)
<b>Stormwater Management Concept (continued)</b>		
<b>Within Or Serving Subject Property (Phase, or Site) (continued)</b>		
Channel Improvements (continued)	<p><b>Existing channels (small creeks):</b> Are these used? <input type="checkbox"/> No <input type="checkbox"/> Yes If “yes” provide the information below.</p>	
	<p>Will small creeks and their floodplains remain undisturbed? <input type="checkbox"/> Yes <input type="checkbox"/> No How many disturbance instances? _____ Identify each planned location:</p>	
	<p>For each location, describe length and general type of proposed improvement (including floodplain changes):</p>	
	<p>For each location, describe section shape &amp; area, flow line slope (min. &amp; max.), surfaces, and 100-year design flow.</p>	
	<p><b>Watercourses (and tributaries):</b> Aside from fringe changes, are Regulatory Watercourses proposed to be altered? <input type="checkbox"/> No <input type="checkbox"/> Yes Explain below.</p>	
	<p>Submit full report describing proposed changes to Regulatory Watercourses. Address existing and proposed section size and shape, surfaces, alignment, flow line changes, length affected, and capacity, and provide full documentation of analysis procedures and data. Is full report submitted? <input type="checkbox"/> Yes <input type="checkbox"/> No If “no” explain:</p>	
	<p><b>All Proposed Channel Work:</b> For all proposed channel work, provide information requested in next three boxes.</p>	
	<p>If design is to replicate natural channel, identify location and length here, and describe design in Special Design section of this Part of Report.</p>	
	<p>Will 100-year flow be contained with one foot of freeboard? <input type="checkbox"/> Yes <input type="checkbox"/> No If not, identify location and explain:</p>	
	<p>Are ROW / easements sized to contain channel and required maintenance space? <input type="checkbox"/> Yes <input type="checkbox"/> No If not, identify location(s) and explain:</p>	

# SECTION IX

## APPENDIX D – TECHNICAL DESIGN SUMMARY

<b>Part 4 – Drainage Concept and Design Parameters</b>		Continued (Page 4.9)			
<b>Stormwater Management Concept (continued)</b>					
<b>Within Or Serving Subject Property (Phase, or Site) (continued)</b>					
Are Detention Facilities Proposed? _____ No _____ Yes	How many facilities for subject property project? _____ For each provide info. below.				
	For each dry-type facility:	Facility 1		Facility 2	
	Acres served & design volume + 10%				
	100-yr volume: free flow & plugged				
	Design discharge (10 yr & 25 yr)				
	Spillway crest at 100-yr WSE?	_____ yes _____ no		_____ yes _____ no	
	Berms 6 inches above plugged WSE?	_____ yes _____ no		_____ yes _____ no	
	Explain any "no" answers:				
	For each facility what is 25-yr design Q, and design of outlet structure?				
	Facility 1:				
	Facility 2:				
	Do outlets and spillways discharge into a public facility in easement or ROW?				
Facility 1: _____ Yes _____ No      Facility 2: _____ Yes _____ No					
If "no" explain:					
For each, what is velocity of 25-yr design discharge at <u>outlet</u> ? & at <u>spillway</u> ?					
Facility 1: _____ & _____      Facility 2: _____ & _____					
Are energy dissipation measures used? _____ No _____ Yes Describe type and location:					
For each, is spillway surface treatment other than concrete? Yes or no, and describe:					
Facility 1:					
Facility 2:					
For each, what measures are taken to prevent erosion or scour at receiving facility?					
Facility 1:					
Facility 2:					
If berms are used give heights, slopes and surface treatments of sides.					
Facility 1:					
Facility 2:					

# SECTION IX

## APPENDIX D – TECHNICAL DESIGN SUMMARY

<b>Part 4 – Drainage Concept and Design Parameters</b>		Continued (Page 4.10)		
<b>Stormwater Management Concept (continued)</b>				
<b>Within Or Serving Subject Property (Phase, or Site) (continued)</b>				
Detention Facilities (continued)	Do structures comply with B-CS Specifications? Yes or no, and explain if “no”: Facility 1;			
	Facility 2:			
	For additional facilities provide all same information on a separate sheet.			
Are parking areas to be used for detention? ____ No ____ Yes What is maximum depth due to required design storm?				
Are culverts used at private crossings?  Yes ____ No ____	<b>Roadside Ditches:</b> Will culverts serve access driveways at roadside ditches? ____ No ____ Yes If “yes”, provide information in next two boxes.			
	Will 25-yr. flow pass without flowing over driveway in all cases? ____ Yes ____ No			
	Without causing flowing or standing water on public roadway? ____ Yes ____ No			
	Designs & materials comply with B-CS Technical Specifications? ____ Yes ____ No			
	Explain any “no” answers:			
	Are culverts parallel to public roadway alignment? ____ Yes ____ No Explain:			
	<b>Creeks at Private Drives:</b> Do private driveways, drives, or streets cross drainage ways that serve Above-Project areas or are in public easements/ ROW? ____ No ____ Yes If “yes” provide information below.			
	How many instances? _____ Describe location and provide information below.			
	Location 1:			
	Location 2:			
Location 3:				
For each location enter value for:		1	2	3
Design year passing without toping travelway?				
Water depth on travelway at 25-year flow?				
Water depth on travelway at 100-year flow?				
For more instances describe location and same information on separate sheet.				

# SECTION IX

## APPENDIX D – TECHNICAL DESIGN SUMMARY

<b>Part 4 – Drainage Concept and Design Parameters</b>	Continued (Page 4.11)			
<b>Stormwater Management Concept (continued)</b>				
<b>Within Or Serving Subject Property (Phase, or Site) (continued)</b>				
Are culverts used at public roadway crossings? _____ No _____ Yes _____ (for more instances of any type describe location and same information on separate sheet)	<b><u>Named Regulatory Watercourses (&amp; Tributaries):</u></b> Are culverts proposed on these facilities? _____ No _____ Yes, then provide full report documenting assumptions, criteria, analysis, computer programs, and study findings that support proposed design(s). Is report provided? _____ Yes _____ No If “no”, explain:			
	<b><u>Arterial or Major Collector Streets:</u></b> Will culverts serve these types of roadways? _____ No _____ Yes How many instances? _____ For each identify the location and provide the information below. Instance 1: Instance 2: Instance 3:			
	Yes or No for the 100-year design flow:	1	2	3
	Headwater WSE 1 foot below lowest curb top?			
	Spread of headwater within ROW or easement?			
	Is velocity limited per conditions (Table C-11)?			
	Explain any “no” answer(s):			
	<b><u>Minor Collector or Local Streets:</u></b> Will culverts serve these types of streets? _____ No _____ Yes How many instances? _____ for each identify the location and provide the information below: Instance 1: Instance 2: Instance 3:			
	For each instance enter value, or “yes” / “no” for:	1	2	3
	Design yr. headwater WSE 1 ft. below curb top?			
	100-yr. max. depth at street crown 2 feet or less?			
	Product of velocity (fps) & depth at crown (ft) = ?			
	Is velocity limited per conditions (Table C-11)?			
	Limit of down stream analysis (feet)?			
	Explain any “no” answers:			

# SECTION IX

## APPENDIX D – TECHNICAL DESIGN SUMMARY

<b>Part 4 – Drainage Concept and Design Parameters</b>		Continued (Page 4.12)
<b>Stormwater Management Concept (continued)</b>		
<b>Within Or Serving Subject Property (Phase, or Site) (continued)</b>		
Culverts (continued)	<b>All Proposed Culverts:</b> For all proposed culvert facilities (except driveway/roadside ditch intersects) provide information requested in next eight boxes.	
	Do culverts and travelways intersect at 90 degrees? <input type="checkbox"/> Yes <input type="checkbox"/> No If not, identify location(s) and intersect angle(s), and justify the design(s):	
	Does drainage way alignment change within or near limits of culvert and surfaced approaches thereto? <input type="checkbox"/> No <input type="checkbox"/> Yes If "yes" identify location(s), describe change(s), and justification:	
	Are flumes or conduit to discharge into culvert barrel(s)? <input type="checkbox"/> No <input type="checkbox"/> Yes If yes, identify location(s) and provide justification:	
	Are flumes or conduit to discharge into or near surfaced approaches to culvert ends? <input type="checkbox"/> No <input type="checkbox"/> Yes If "yes" identify location(s), describe outfall design treatment(s):	
	Is scour/erosion protection provided to ensure long term stability of culvert structural components, and surfacing at culvert ends? <input type="checkbox"/> Yes <input type="checkbox"/> No If "no" Identify locations and provide justification(s):	
	Will 100-yr flow and spread of backwater be fully contained in street ROW, and/or drainage easements/ ROW? <input type="checkbox"/> Yes <input type="checkbox"/> No if not, why not?	
	Do appreciable hydraulic effects of any culvert extend downstream or upstream to neighboring land(s) not encompassed in subject property? <input type="checkbox"/> No <input type="checkbox"/> Yes If "yes" describe location(s) and mitigation measures:	
	Are all culvert designs and materials in compliance with B-CS Tech. Specifications? <input type="checkbox"/> Yes <input type="checkbox"/> No If not, explain in Special Design Section of this Part.	



# SECTION IX

## APPENDIX D – TECHNICAL DESIGN SUMMARY

<b>Part 4 – Drainage Concept and Design Parameters</b>		Continued (Page 4.13)
<b>Stormwater Management Concept (continued)</b>		
<b>Within Or Serving Subject Property (Phase, or Site) (continued)</b>		
Bridge(s)	Is a bridge included in plans for subject property project? <input type="checkbox"/> No <input type="checkbox"/> Yes If "yes" provide the following information.	
	Name(s) and functional classification of the roadway(s)?	
	What drainage way(s) is to be crossed?	
	A full report supporting all aspects of the proposed bridge(s) (structural, geotechnical, hydrologic, and hydraulic factors) must accompany this summary report. Is the report provided? <input type="checkbox"/> Yes <input type="checkbox"/> No If "no" explain:	
Water Quality	Is a Stormwater Pollution Prevention Plan (SW3P) established for project construction?  <input type="checkbox"/> No <input type="checkbox"/> Yes	Provide a general description of planned techniques:
<b>Special Designs – Non-Traditional Methods</b>		
Are any non-traditional methods (aquatic ecosystems, wetland-type detention, natural stream replication, BMPs for water quality, etc.) proposed for any aspect of subject property project? <input type="checkbox"/> No <input type="checkbox"/> Yes If "yes" list general type and location below.		
Provide full report about the proposed special design(s) including rationale for use and expected benefits. Report must substantiate that stormwater management objectives will not be compromised, and that maintenance cost will not exceed those of traditional design solution(s). Is report provided? <input type="checkbox"/> Yes <input type="checkbox"/> No If "no" explain:		

# SECTION IX

## APPENDIX D – TECHNICAL DESIGN SUMMARY

<b>Part 4 – Drainage Concept and Design Parameters</b>	Continued (Page 4.14)
<b>Stormwater Management Concept (continued)</b>	
<b>Within Or Serving Subject Property (Phase, or Site) (continued)</b>	
<b>Special Designs – Deviation From B-CS Technical Specifications</b>	
<p>If any design(s) or material(s) of traditional runoff-handling facilities deviate from provisions of B-CS Technical Specifications, check type facility(ies) and explain by specific detail element.</p> <p> <input type="checkbox"/> Detention elements    <input type="checkbox"/> Drain system elements    <input type="checkbox"/> Channel features  <input type="checkbox"/> Culvert features    <input type="checkbox"/> Swales    <input type="checkbox"/> Ditches    <input type="checkbox"/> Inlets    <input type="checkbox"/> Outfalls  <input type="checkbox"/> Valley gutters    <input type="checkbox"/> Bridges (explain in bridge report)         </p>	
In table below briefly identify specific element, justification for deviation(s).	
Specific Detail Element	Justification for Deviation (attach additional sheets if needed)
1)	
2)	
3)	
4)	
5)	
<p>Have elements been coordinated with the City Engineer or her/his designee? For each item above provide “yes” or “no”, action date, and staff name:</p> <p>1)</p> <p>2)</p> <p>3)</p> <p>4)</p> <p>5)</p>	
<b>Design Parameters</b>	
<b>Hydrology</b>	
Is a map(s) showing all Design Drainage Areas provided? <input type="checkbox"/> Yes <input type="checkbox"/> No	
Briefly summarize the range of applications made of the Rational Formula:	
What is the size and location of largest Design Drainage Area to which the Rational Formula has been applied?    _____ acres    Location (or identifier):	

# SECTION IX

## APPENDIX D – TECHNICAL DESIGN SUMMARY

<b>Part 4 – Drainage Concept and Design Parameters</b>	Continued (Page 4.15)				
<b>Design Parameters (continued)</b>					
<b>Hydrology (continued)</b>					
In making determinations for time of concentration, was segment analysis used? ____ No ____ Yes    In approximately what percent of Design Drainage Areas? _____ %					
As to intensity-duration-frequency and rain depth criteria for determining runoff flows, were any criteria other than those provided in these Guidelines used? ____ No ____ Yes    If “yes” identify type of data, source(s), and where applied:					
For each of the stormwater management features listed below identify the storm return frequencies (year) analyzed (or checked), and that used as the basis for design.					
Feature	Analysis Year(s)	Design Year			
Storm drain system for arterial and collector streets					
Storm drain system for local streets					
Open channels					
Swale/buried conduit combination in lieu of channel					
Swales					
Roadside ditches and culverts serving them					
Detention facilities: spillway crest and its outfall					
Detention facilities: outlet and conveyance structure(s)					
Detention facilities: volume when outlet plugged					
Culverts serving private drives or streets					
Culverts serving public roadways					
Bridges: provide in bridge report.					
<b>Hydraulics</b>					
What is the range of design flow velocities as outlined below?					
Design flow velocities;	Gutters	Conduit	Culverts	Swales	Channels
Highest (feet per second)					
Lowest (feet per second)					
<b>Streets and Storm Drain Systems</b> Provide the summary information outlined below:					
Roughness coefficients used:      For street gutters: _____					
For conduit type(s) _____      Coefficients: _____					

# SECTION IX

## APPENDIX D – TECHNICAL DESIGN SUMMARY

<b>Part 4 – Drainage Concept and Design Parameters</b>	Continued (Page 4.16)
<b>Design Parameters (continued)</b>	
<b>Hydraulics (continued)</b>	
<b>Street and Storm Drain Systems (continued)</b>	
<p>For the following, are assumptions other than allowable per Guidelines?          Inlet coefficients? <input type="checkbox"/> No <input type="checkbox"/> Yes    Head and friction losses <input type="checkbox"/> No <input type="checkbox"/> Yes          Explain any “yes” answer:</p>	
<p>In conduit is velocity generally increased in the downstream direction? <input type="checkbox"/> Yes <input type="checkbox"/> No          Are elevation drops provided at inlets, manholes, and junction boxes? <input type="checkbox"/> Yes <input type="checkbox"/> No          Explain any “no” answers:</p>	
<p>Are hydraulic grade lines calculated and shown for design storm? <input type="checkbox"/> Yes <input type="checkbox"/> No          For 100-year flow conditions? <input type="checkbox"/> Yes <input type="checkbox"/> No    Explain any “no” answers:</p>	
<p>What tailwater conditions were assumed at outfall point(s) of the storm drain system? Identify each location and explain:</p>	
<p><b>Open Channels</b> If a HEC analysis is utilized, does it follow Sec VI.F.5.a? <input type="checkbox"/> Yes <input type="checkbox"/> No</p>	
<p>Outside of straight sections, is flow regime within limits of sub-critical flow? <input type="checkbox"/> Yes <input type="checkbox"/> No          If “no” list locations and explain:</p>	
<p><b>Culverts</b> If plan sheets do not provide the following for each culvert, describe it here.</p>	
<p>For each design discharge, will operation be outlet (barrel) control or inlet control?</p>	
<p>Entrance, friction and exit losses:</p>	
<p><b>Bridges</b> Provide all in bridge report</p>	

# SECTION IX

## APPENDIX D – TECHNICAL DESIGN SUMMARY

<b>Part 4 – Drainage Concept and Design Parameters</b>	Continued (Page 4.17)
<b>Design Parameters (continued)</b>	
<b>Computer Software</b>	
What computer software has been used in the analysis and assessment of stormwater management needs and/or the development of facility designs proposed for subject property project? List them below, being sure to identify the software name and version, the date of the version, any applicable patches and the publisher	
<b>Part 5 – Plans and Specifications</b>	
Requirements for submittal of construction drawings and specifications do not differ due to use of a Technical Design Summary Report. See Section III, Paragraph C3.	
<b>Part 6 – Conclusions and Attestation</b>	
<b>Conclusions</b>	
Add any concluding information here:	
<b>Attestation</b>	
Provide attestation to the accuracy and completeness of the foregoing 6 Parts of this Technical Design Summary Drainage Report by signing and sealing below.	
<i>“This report (plan) for the drainage design of the development named in Part B was prepared by me (or under my supervision) in accordance with provisions of the Bryan/College Station Unified Drainage Design Guidelines for the owners of the property. All licenses and permits required by any and all state and federal regulatory agencies for the proposed drainage improvements have been issued or fall under applicable general permits.”</i>	
(Affix Seal)	
_____	
Licensed Professional Engineer	
State of Texas PE No. _____	

# **Appendix E Best Management Practices**

## **Unified Stormwater Design Guidelines**

**City of College Station  
City of Bryan**

**AUGUST 2012**

As defined in Section VIII of these Guidelines, improving stormwater quality is a worthy objective. At key points, the Guidelines encourage special designs aimed at improving the quality of stormwater discharged into the region's major streams and waterways. Specific details for such designs are not stipulated. Rather, applications are left to the creativity of qualified engineers and environmental specialists who serve the development community.

This Appendix is provided in order to facilitate and foster design solutions that will help improve water quality. The effectiveness of the techniques outlined herein is very dependent on proper application and implementation, and is in no way assured. Likewise their use does not assure achieving public safety objectives, and can work against those objectives if improperly conceived or deployed.

Special designs may propose using any of the examples outlined herein or other techniques that may have been implemented in other jurisdictions. It is highly recommended that any special design concepts be carefully coordinated with the City Engineer or his/her designee as early as possible in design processes. It shall be the designers' responsibility to substantiate that the special design does not compromise public safety objectives or aggravate long term maintenance requirements.

#### **“Best Management Practices”**

In their publication “National Menu of Best Management Practices For Storm Water Phase II”, the US Environmental Protection Agency (EPA) has advanced a number of concepts for managing urban stormwater runoff in a manner that will enhance water quality. The techniques are intended to provide guidance to regulated small MS4s. This Appendix provides a brief introduction to several of those techniques. They are offered only as examples. There is no requirement to use them, nor are they specifically recommended over other potential design solutions. Likewise, designers should not limit their thinking to only these examples.

All of the techniques offered by the EPA have been used at various locations and have been scientifically evaluated for their general effectiveness. The specific chemical or physical effectiveness of the techniques is beyond the scope of these Guidelines, as are their advantages and disadvantage in terms of initial cost, comparative costs, or maintenance ramifications. Nevertheless, these later issues must be addressed in technical reports substantiating special design proposals. The designers' attention is directed to the aforementioned publication for the information necessary to implement these and other techniques.

#### **Retention / Irrigation Basins**

Retention refers to the idea of capturing stormwater and retaining it, as opposed to simply collecting it and metering its release at some pre-determined flow rate. As suggested by the title, the concept of this technique is to collect runoff into a holding pond and then draw from it to irrigate landscaped areas. The intent is to replicate natural situations where the majority of rainfall is infiltrated into the soil or underlying groundwater, and pollutants are captured by soils. In addition, particles settle while the water is pooled.

### **Extended Detention Basins**

A traditional detention facility captures storm flow and releases it at a pre-determined rate, one associated with pre-development conditions, with no particular consideration for water quality objectives. An “extended detention basin” functions in a similar way but is designed to release the collected water at a much slower rate, one that causes the water to remain pooled much longer, usually on the order of 24 hours. This allows time for suspended solids to settle, and can derive other water quality benefits. Such a facility should serve no more than 100 acres, and generally requires a slower release rate and a larger storage volume than a traditional detention facility.

### **Grassy Swales**

A grassy swale is a specially designed channel. With very flat side slopes (4:1 or flatter), it is wider than it is deep. The flow line slope should be between one percent and five percent, and the surfaces must be covered with vegetation, generally close-growing, water-resistant grasses. The idea is simple: as runoff flows over and through the grass at a shallow depth and slow rate, particles tend to settle and biological uptake of pollutants tends to occur.

### **Vegetative Filter Strips**

As suggested by the name, this technique involves long strips of vegetated area placed so that runoff will traverse their length in route to lower areas. The idea is to bring runoff to the strips in broad sheet flow or in uniform shallow overland flow, not in a concentrated manner. As stormwater moves through the strip(s) in very shallow flow at a slow rate, the vegetation tends to cause particles to settle and biological filtration of pollutants.

### **Sand Filter Systems**

These systems can vary widely in their design but in any case require carefully specified and constructed components in order to be effective. Generally, two chambers are required, one for sedimentation and another for filtration. Runoff first enters the sedimentation chamber where larger solids are collected. Next it seeps through the sand bed in the filtration chamber. There, a specially designed sand bed composed of sand, gravel, and filter fabric in just the right combinations and having just the right physical characteristics, captures a range of other pollutants. Water is finally released through perforated collection pipe(s) situated beneath the sand bed system.

A “full sedimentation” system includes a wall with a riser pipe between the two chambers. This type requires the first chamber to be sized for the entire design capture volume. A “partial sedimentation” system includes a porous separation between the two chambers so larger solids may not pass into the filtration chamber. In this type, the two chambers together are sized for the entire design capture volume.



#### **Wet Basins**

In simplest terms a wet basin is designed to retain a pool of water year-round. Whereas a traditional detention facility has an outlet near its bottom, a wet basin has an outlet located near its top. With no lower outlet, the facility must fill to the level of the top outlet before any water is released, and it does not drain. In addition, a wet basin typically has a standing crop of water-tolerant vegetation along its usual waterline.

A wet basin should have two components: a sediment forebay and a main pool. Runoff first moves through the forebay where gross solids are captured. It then fills the main pool basin until overflowing through an outlet spillway. Properly sized, such a basin will capture the desired volume of water before allowing discharge. In this way it acts as a stilling basin allowing solids to settle. One objective is for the aquatic environment to eliminate pollutants through wetland plant uptake and microbial degradation. In dry climates supplemental water sources may be necessary in order to maintain a pool level supportive of the aquatic environment.

#### **Constructed Wetlands**

The concept of a constructed wetland is to gain the pollutant removal characteristics of a natural wetland environment. Among these are settling of solids, wetland plant uptake, and microbial degradation. Extremely wide variations in design are possible. The facility is similar to a wet basin because it must be wet year-round, but it is shallow and marsh-like, creating conditions supporting abundant vegetation and microbial population. Micro-pools, small islands for waterfowl habitat, and multiple species of trees, shrubs, and plants are among the design elements that must be balanced for the facility to be successful.

A constructed wetland has four principal components: a splitter box, a sedimentation forebay, the wetland zone (“pond”), and the outlet structure. The splitter box diverts flow from the main flow path to the entrance, keeping away anything more than the design flow (usually a 25-year storm). From the splitter box, runoff moves into the forebay where gross solids are captured before flowing into the wetland zone. In the wetland zone, runoff moves through multiple irregular flow paths and micro-pool areas filling the wetland “pond” to no more than two feet above its usual water surface elevation. The outlet structure must allow the water level to gradually decrease to its normal elevation. If storm flow rushes through the facility or keeps it inundated too long, the aquatic ecosystem can be damaged. In dry climates supplemental water sources may be necessary in order to maintain a water level supportive of the aquatic environment.

# **Appendix F**

## **Quality Control**

### **Unified Stormwater Design Guidelines**

**City of College Station  
City of Bryan**

**AUGUST 2012**

# SECTION IX

## APPENDIX F – QUALITY CONTROL

### BEST MANAGEMENT PRACTICES – STORMWATER QUALITY CONTROLS

	<b>Construction Stages / Sequencing</b>	<b>Non-Structural</b>	<b>Structural</b>
1	Pre-construction / Survey clearing / limited ground disturbance	<ul style="list-style-type: none"> <li>• Establishment of Trees to protect (if desired)</li> <li>• Limited equipment (no tracked equipment)– no significant ground vegetation disturbance</li> </ul>	
2	Install Detention Facilities – rough graded to capture runoff	<ul style="list-style-type: none"> <li>• Install waste receptacles on site</li> <li>• Temporary Sanitary Facilities (port-a-potties)</li> <li>• Designate concrete / equipment washout area</li> <li>• Install Temporary Construction Access</li> <li>• Install storm sewer inlet protection (existing inlets)</li> </ul>	<ul style="list-style-type: none"> <li>• Silt Retention Devices (ex. Silt fence, check dams)</li> <li>• Sedimentation Traps / ponds / baffles</li> <li>• Rough grade detention ponds</li> <li>• Outlet structure installed</li> <li>• Slope protection measures</li> </ul>
3	Full Clearing and Grading	<ul style="list-style-type: none"> <li>• Dust Control (wetting disturbed areas) (daily)</li> <li>• Street Sweeping (daily)</li> </ul>	<ul style="list-style-type: none"> <li>• Maintain Silt Retention Devices</li> <li>• Rough Grade property to drain to ponds</li> <li>• Slope protection measures</li> </ul>
4	Utility Infrastructure & Drainage System	<ul style="list-style-type: none"> <li>• New Storm inlet protection</li> <li>• Proper directing of rainwater pumping from construction ditches</li> </ul>	<ul style="list-style-type: none"> <li>• storm sewers / inlets</li> <li>• Detention Pond</li> <li>• Onsite Utilities installed</li> </ul>
5	Site Development (buildings)	<ul style="list-style-type: none"> <li>• Utilize washout areas</li> <li>• Maintain trash and sanitary facilities</li> <li>• Installation of roof gutters directed to storm system</li> <li>• Dust Control (wetting disturbed areas) (daily)</li> <li>• Street Sweeping (daily)</li> </ul>	<ul style="list-style-type: none"> <li>• Install paving on site (minimize erosion) – done before building foundations</li> </ul>
6	Site Stabilization	<ul style="list-style-type: none"> <li>• Maintenance Bond (1 year) provided to cover public infrastructure and final site stabilization</li> </ul>	<ul style="list-style-type: none"> <li>• Full grass / landscape coverage and establishment</li> <li>• Removal of silt retention devices upon grass establishment</li> </ul>

# **Appendix G**

## **Glossary**

### **Unified Stormwater Design Guidelines**

**City of College Station  
City of Bryan**

**AUGUST 2012**

### Abbreviated Drainage Plan

A brief written plan stating and schematically showing how a small proposed **land development project** will satisfy stormwater management requirements of these **Guidelines**. Generally this is applicable only to projects that will be devoid of detention facilities and public stormwater infrastructure of any kind. This may be accomplished with a site plan showing vertical dimensional controls or a site grading plan.

### Above-Project Area

Land area(s) adjoining or near a proposed **land development project** that contributes stormwater runoff to, or through, the project at the time of hydrologic analysis or in the future. Above-project areas are included in the **drainage study area**.

### Anticipated Development

Full potential urbanization of a **basin** or **watershed** area in compliance with the Comprehensive Plan. Such an area may include one or more subdivisions, one or multiple property holdings, wholly undeveloped land or both developed and undeveloped land areas.

### Area Engineer

The Bryan District Office of the Texas Department of Transportation (TxDOT) operates several Area Offices, each of which has responsibility for several counties. The engineer in charge of each Area Office has the title of **Area Engineer**.

### Areas (Hydrologic)

For uniformity of meaning within these **Guidelines** land areas are defined according to the general hierarchy listed below. Specific definitions of each are included in the Glossary.

**Watershed** (area)

**Basin** (area)

**Drainage Study Area**

**Project Area**

**Above-Project Area**

**Pathway Area**

**Design Drainage Area**

### Base Flood

The flood having a one percent chance of being equaled or exceeded in any given year, also known as “100 year” flood.

### Basin

A land area making up a portion of a **watershed**. A basin can be thought of as the entire area contributing storm flow to a **watercourse** serving as a tributary to a **principal named stream**. Several basins usually comprise a **watershed**.

### **B-CS Technical Specifications**

All items pertinent to design or construction of stormwater facilities of any kind included in the latest adopted version of the Bryan-College Station Unified Technical Specifications and Standard Details. See “**Technical Specifications**”

### **Buildout Condition**

Full completion of any land development project in all of its phases, if any, representing the entire contiguously owned tract(s), whether proposed for near-term or possible future development. This refers to: completion of any single-lot site project; the final completion of any multi-stage project entailing a site project staged over time; or final completion of multiple subdivision projects collectively making up a parent tract (or preliminary plat submittal) representing ownership of an un-platted parcel of land regardless of size.

### **BFE – Base Flood Elevation**

The high water surface elevation(s) along a **watercourse** resulting from the **base flood** passing down that **watercourse**.

**CFS** A measure of water flow in cubic feet per second

**City** Either the City of Bryan or the City of College Station as applicable

### **City Engineer**

The official city engineer of Bryan or College Station as applicable

### **Cities**

The cities of Bryan and College Station collectively, or each individually.

### **CLOMR**

Conditional Letter of Map Revision as related to **FEMA** requirements for managing **FEMA**-designated flood prone areas

### **Comprehensive Plan**

The urban general plan officially adopted by the **City**

### **Conveyance Pathway**

An identifiable route by which concentrated (non-sheet flow) stormwater will travel within and from a **project area** to a discharge point at a main channel of the Primary Drainage System

### **County Engineer**

The principal person in Brazos County government who has responsibility for engineering decisions.

### **Conveyance Pathway Area**

See “**Pathway Area**”

**Datum** Any level surface to which elevations are referred (for example, mean sea level); is also referred to as datum plane, although it is not actually a plane

**Design Drainage Area**

The surface area contributing stormwater runoff to any particular point of design in a stormwater management system of any kind. Examples can range in size from the area contributing to a single curb inlet, to that contributing to a flood control facility astride a major stream. Depending on the point of design, the design drainage area can equal an entire **watershed**, an entire **basin**, a **drainage study area**, an **off-project area**, a **project area** or portion(s) of any of these areas.

**Detention**

Temporary storage and metered release of stormwater

**Detention Facility**

A permanent facility designed for the temporary storage and metered release of stormwater without creating a permanent pool of water.

**Discharge**

Stormwater out flow from an area of any kind, or from a storm water feature such as a conduit or a detention facility.

**Drainage Development Permit**

A permit issued by the **City** that allows the start of clearing, grubbing, or earthwork as the early stage(s) of a land development project, based on an approved **drainage plan** or an approved **abbreviated drainage plan**.

**Drainage Easement**

An interest in land granted to the **City** for the maintenance of a **drainage facility**, on which certain uses are prohibited; and providing for the entry and operation of machinery and vehicles for maintenance purposes.

**Drainage Facilities**

All elements (public and private) necessary to manage and convey stormwater runoff from its initial contact with earth to its disposition in a **watercourse** making up the primary drainage system of the Bryan-College Station area. These may include but are not limited to storm sewers, improved channels, unimproved drainage ways, areas within **drainage easements** or **drainage right of way** providing concentrated or overland sheet flow, and all appurtenances to the foregoing, such as inlets, manholes, junction boxes, headwalls, culverts, etc.

**Drainage Plan**

A detailed representation of how stormwater will be managed as part of a proposed **land development project** (site or subdivision). Usually accompanied by (or incorporated into) an engineering report, it is to be based on an approved **preliminary drainage plan**

### **Drainage Report**

A report, prepared by a Registered Professional Engineer, that presents the **drainage plan** for a **land development project** (site or subdivision) in compliance with the provisions of these **Guidelines**. It must document the hydrologic and hydraulic analyses accomplished to address the **project area**, **above-project area(s)** and **pathway area(s)**, and any watercourse conveying stormwater to or from the **project area**.

### **Drainage Study**

See “**Drainage Report**”.

### **Drainage Study Area**

The full extent of land area that must be analyzed for the effects of stormwater runoff, whether part of a project, upland of the project, or contributing stormwater runoff to the **conveyance pathway** downstream of the project. The drainage study area is equal in size to the sum of the **project area**, the **above-project area**, if any, and the **pathway area**, if any.

### **Drainage Right Of Way**

An area of land dedicated to the **City** for the purposes of conveying and containing stormwater flow, constructing drainage facilities, and/or allowing entry and/or operation of equipment for maintaining such drainage features and facilities.

### **Elevation**

The vertical distance from a datum, usually the NGVD, to a point or object. For example, if the elevation of point “A” is 802.46 feet, point “A” is 802.46 feet above some datum.

### **Encroachment**

Existing or proposed buildings, foundations, drainage structures, streets (including bridges and culverts), utilities, or earthwork of any kind which is situated in **floodplain**, or **flood fringe** areas, the geographic limits of which are defined on the official **Flood Insurance Rate Maps** of the **City**.

### **Equal Encroachment**

Equitable **encroachment** into **floodplain** or **flood fringe** areas along a significant reach of both sides of a **watercourse**, as a function of “low side” and “high side” hydrologically proportionate areas.

### **Engineer**

A Registered Professional Engineer duly authorized and licensed, under provisions of the Texas Engineering Practice Act, to practice the profession of engineering.

### **Erosion**

The process whereby the surface of the earth is loosened and carried away by the action of wind, water, gravity, ice, or a combination thereof.



### Existing Condition

The hydrologic condition of the **project area** or the **drainage study area** that exists (or existed) prior to any proposed land development work and at the time for which a hydrologic analysis is conducted. Where man-made topographic features predate adoption of these **Guidelines**, such features shall be considered “existing condition”.

### Extraterritorial Jurisdiction (ETJ)

Within the terms of the Texas Municipal Annexation Act, means the unincorporated area, not a part of any other city, which is contiguous to the Corporate Limits of the **City**, the outer boundaries of which are measured from the extremities of the corporate limits of the **City** outward for such distances as may be stipulated in the Texas Municipal Annexation Act, in which area, within the terms of the act, the **City** may enjoin the violation of its subdivision control ordinance.

**FEMA** Federal Emergency Management Agency of the US Government

**F.H.A.** Federal Housing Administration, an agency of the US Government.

### Flood Insurance Map

See “**Flood Insurance Rate Map**”

### Flood Insurance Rate Map

Any of a series of maps published by **FEMA** that depicts the geographic limits of flood prone areas along the principle **watercourses** of the **Cities**, for the purpose of identifying those areas in which property owners are eligible to participate in the National Flood Insurance Program.

### Floodplain

Overbank areas along a **watercourse** that are subject to inundation by stormflow due to unusually larger storms events.

### Flood Study

The official study, or collection of studies, that defines the **flood plains**, **flood fringe**, and **floodways** of the primary drainage system and tributaries thereof as required in connection with the National Flood Insurance Program sponsored by **FEMA**.

### Floodway

The channel and adjacent overbank areas of a river or other **watercourse** that may not be filled or hydraulically altered if such fill or alterations will cause a cumulatively increase in the **base flood elevation** of more than one foot.

### Freeboard

That portion of a channel bank, detention embankment, or other stormwater management facility that is above the water surface elevation expected to be generated by the design storm for which the facility is designed.

### **Guidelines**

The design guidelines referenced in this document: “Bryan and College Station Uniform Stormwater Design Guidelines”

### **Hydraulics**

A branch of science that deals with practical applications (such as the transmission of energy or the efforts of flow) of liquid (such as water) in motion

### **Hydrology**

A science dealing with the properties, distribution, and circulation of water on the surface of the land, in the soil and underlying rocks, and in the atmosphere

### **Land Development Project**

Any proposed site development or subdivision project requiring building permit(s) or platting under provisions of **City** ordinances.

### **Legal Lot**

A parcel of land having been divided from a parent tract via a plat duly processed and approved by the City, and filed of record in county records under the platting provisions of Texas State Law.

**LOMA** Letter of Map Amendment as related to **FEMA** requirements for managing **FEMA**-designated flood prone areas

### **LOMAR**

Letter of Map Revision as related to **FEMA** requirements for managing **FEMA**-designated flood prone areas

### **Lowest Floor**

The lowest floor, or the lowest enclosed area (including basement), of a structure. An unfinished or flood resistant enclosure, usable solely for the parking of vehicles, building access or storage, in an area other than a basement area, is not considered a building's lowest floor, provided that such enclosure is not built so as to render the structure in violation of the applicable non-elevation design requirements of **City** ordinances.

### **Master Drainage Plan**

An official plan of the **City** for comprehensive management of stormwater runoff in an entire **basin** or **watershed**, or in specific **reaches** thereof.

### **Mean Sea Level (MSL)**

The average height of the surface of the sea for all stages of the tide taken over a 19-year period.

### **Named Regulatory Watercourse**

The major watercourses or streams in the Bryan-College Station region having been ascribed with names and listed in Table B-1, Appendix B.

### **Natural Land**

The cover and topography of land before any man-made changes that would substantively affect the path or intensity of stormwater runoff.

### **Natural Watercourse**

A stream, waterway, or channel more or less in the alignment created by natural forces, with or without man-made alteration of its surfacing and configuration at limited locations.

### **Pathway Area**

Land area(s) that drain to the **conveyance pathway** of a project, but that are not included in the **project area** or **above-project area(s)**. See **conveyance pathway area**.

### **Principal Named Streams (Watercourses)**

See “**Named Regulatory Watercourses**”

### **Preliminary Drainage Plan**

See “**Preliminary Drainage Report**”

### **Preliminary Drainage Report**

A report showing a schematic representation of how stormwater will be managed as part of a proposed land development project. It will document pertinent topographic, hydrologic, and land ownership characteristics of all land areas contributing stormflow to a **project area**, as well as all hydrologic parameters proposed for analysis of design stormflow throughout the project.

### **Project Area**

The entire land area of a proposed site development or subdivision project, at **buildout condition**, into which buildings, structures, and/or street and utility facilities are to be constructed. This area(s), together with any **above-project area(s)** and **pathway area(s)** make up the **drainage study area** that must be considered in developing plans for stormwater management facilities for the project.

### **Project Site**

See “**Project Area**”

**Reach** A length or portion of a **watercourse**, whether wholly natural or influenced by man-made improvements or alterations.

### **Regional Detention**

A flood control facility approved by the **City** as a mechanism for managing stormwater runoff from a large land area comprised of one or more subdivisions, one or multiple property holdings, developed and undeveloped land areas, or any combination of such areas.

### **Regulatory Watercourses**

See “**Named Regulatory Watercourses**”

### **Regulatory Watershed**

The total land area that contributes stormwater runoff to a **named regulatory watercourse** in the Bryan-College Station region. Each such watercourse has a watershed area that is made up of **basins**. The sum of the land area(s) in a watershed's **basins** equals the land area of the watershed.

### **Retention Facility**

A facility that provides for the storage of stormwater flows by means of a permanent pool of water or a permanent pool in conjunction with a temporary storage component.

### **Right of Way**

Land set aside for street and storm drain facilities or utilities, or exclusively for stormwater management purposes.

### **Rural Residential**

A term referring to a category of land use zoning. See **Urban Estates**.

### **Rural Subdivision**

An area of land divided by platting into lots none of which are smaller than one (1) acre, and which is served by roadways having a rural cross section (one characterized by presence of roadside ditches and no curb and gutter). See also **Urban Estates**.

### **Sedimentation**

Deposits of detached soil particles or rock fragments after being transported from their site or origin by runoff water.

**Site** See "**Site Project**".

### **Site Project**

A land area consisting of a single platted lot or two or more contiguous platted lots upon which a building project is planned, consisting of building structures, parking, and other facilities and exclusive of public streets. A site project may or may not include public utilities situated in easements, or stormwater management facilities situated in drainage right of way. See "**Site**"

### **Special Design**

Any stormwater management facility or technique the design of which is not specifically addressed by these **Guidelines** or the B-CS Technical Specifications.

### **Standard Specifications for Construction**

See **Technical Specifications**

### **Stormwater Planning Conference**

A meeting between property owners/developers (including their representatives) and the **City Engineer** (or his/her designee) for the purpose of identifying how these Guidelines and the provisions of stormwater management ordinances relate to land area(s) proposed for near-term or future development.

### **Structure**

A walled and roofed building that is principally above the ground, as well as a manufactured home.

### **Study Limits**

Associated with a drainage study for a **drainage report**, this is the geographic limits of the hydrologic and hydraulic analyses that are required for the study.

### **Subdivision Project**

A land development project involving the division of land into lots and ROW for public streets and utilities or the dividing of land into individual lots for near term construction or planned long term construction of **site projects**.

### **Surveyor**

A Registered Public Surveyor or Registered Land Surveyor as licensed by the State of Texas.

### **Swale**

A shallow drainage way characterized as having a “V” shape the sides of which have very flat slopes, generally on the order of sides 6 horizontal to 1 vertical (6:1) or flatter.

**TAMU** Texas A&M University

**TAMUS** The Texas A&M University System

### **Technical Design Summary**

A drainage report format that may be used in lieu of a traditional prose report. Following a question/answer process, it is to use the forms provided in Appendix D, with attachments as needed.

### **Technical Specifications**

See “**B-S Technical Specifications**”

### **Tributaries**

Waterways, watercourses, streams, or creeks that directly flow into the Named Regulatory Watercourses of the Bryan and College Station region. Some may be referred to by a name on maps or other reference.

**TxDOT** Texas Department of Transportation.

### **Ultimate Development**

This term generally relates to the extent to which impervious materials and plant growth will, at some future time, cover land contributing stormwater runoff to one or more design points in a stormwater management system. Of necessity this requires some plan or a series of assumptions about future characteristics of undeveloped areas. See **Anticipated Development**

### **Urban Estates**

A class of zoning resulting in single family homes on relatively large lots, generally one acre or larger. See **Rural Subdivision**.

### **Watercourse**

Any depression, channel, storm sewer, or culvert serving to give direction to a current of stormwater.

### **Watershed**

See "**Regulatory Watershed**"

# **Appendix H**

## **General References**

### **Unified Stormwater Design Guidelines**

**City of College Station  
City of Bryan**

**AUGUST 2012**

The following sources were consulted directly or indirectly by reference in the development of these Guidelines:

Drainage Criteria Manual, City of Temple, November 1996.

Drainage Criteria Manual, Montgomery County, 1989.

Drainage Design Guidelines, City of Bryan, 2003.

Drainage Manual, City of Austin, June 1993.

Drainage Policy and Design Standards, City of College Station, 1986

Environmental & Municipal Update, Lloyd Gosselink, Attorneys at Law, April 2005

Environmental & Municipal Update, Lloyd Gosselink, Attorneys at Law, January 2006.

Erosion and Sediment Control Guidelines for Developing Areas in Texas, Soil Conservation Service, US Department of Agriculture.

“Erosion and Sedimentation Control Measures”, short course by Engineering Utilities and Public Works Training Institute, Texas Engineering Extension Service, Texas A&M University System, 2003.

Haestad Method’s Culvert Master

Hydraulic Design Manual, Texas Department of Transportation, November 2002.

Mitigation Guidelines Regulatory Program, Fort Worth District, US Army Corps of Engineers, December 2003.

National Menu of Best Management Practices For Stormwater Phase II, US Environmental Protection Agency, August 2002.

Regulatory Program Overview, Fort Worth District, US Army Corps of Engineers, March 2003



## **SECTION IX**

---

## **APPENDIX H – REFERENCES**

Rossmiller, R.,L. "The Rational Formula Revisited"

Urban Hydrology for Small Watersheds, Technical Release No. 55, Soil Conservation Service (National Resource Conservation Service) US Department of Agriculture, June 1986.

Walsh (1989) from Chow (1959)

Water Resources and Environmental Engineering