

**NOTES:**

1. NO SPLICES IN COPPER TUBING WILL BE ALLOWED BETWEEN THE SERVICE SADDLE AND THE CURB STOP FOR SINGLE SERVICE OR BETWEEN THE SERVICE SADDLE AND THE WYE FOR DOUBLE SERVICE.
2. IT SHALL BE THE RESPONSIBILITY OF THE CONTRACTOR TO PRESSURE TEST LINE IMMEDIATELY AFTER THE STREET CROSSINGS HAVE BEEN INSTALLED.
3. MARK EACH SERVICE END WITH METAL "T" POST PAINTED BLUE.
4. MATERIAL USED SHALL BE AS SPECIFIED OR AN APPROVED EQUAL.
5. ALL CONNECTIONS TO BE COMPRESSION TYPE.
6. ALL SERVICE WYES & EXTENSIONS ARE TO BE INSTALLED WITH THE MAIN LINE CONSTRUCTION.
7. METERS AND VALVE BOXES SHALL BE PLACED BY THE CITY UPON PAYMENT OF FEE.
8. LOT CORNERS SHALL BE MARKED WITH A LATH UNDER THE SUPERVISION F A RPLS UPON COMPLETION OF CONSTRUCTION.

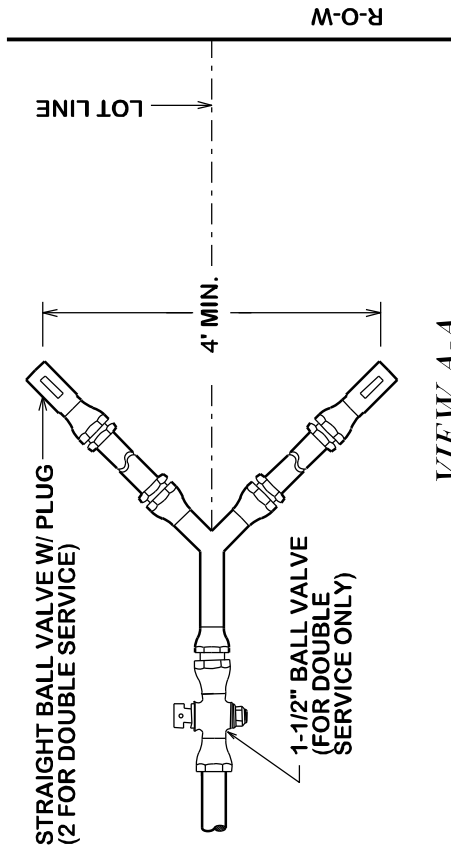

**VIEW A-A**  
**DOUBLE SERVICE**

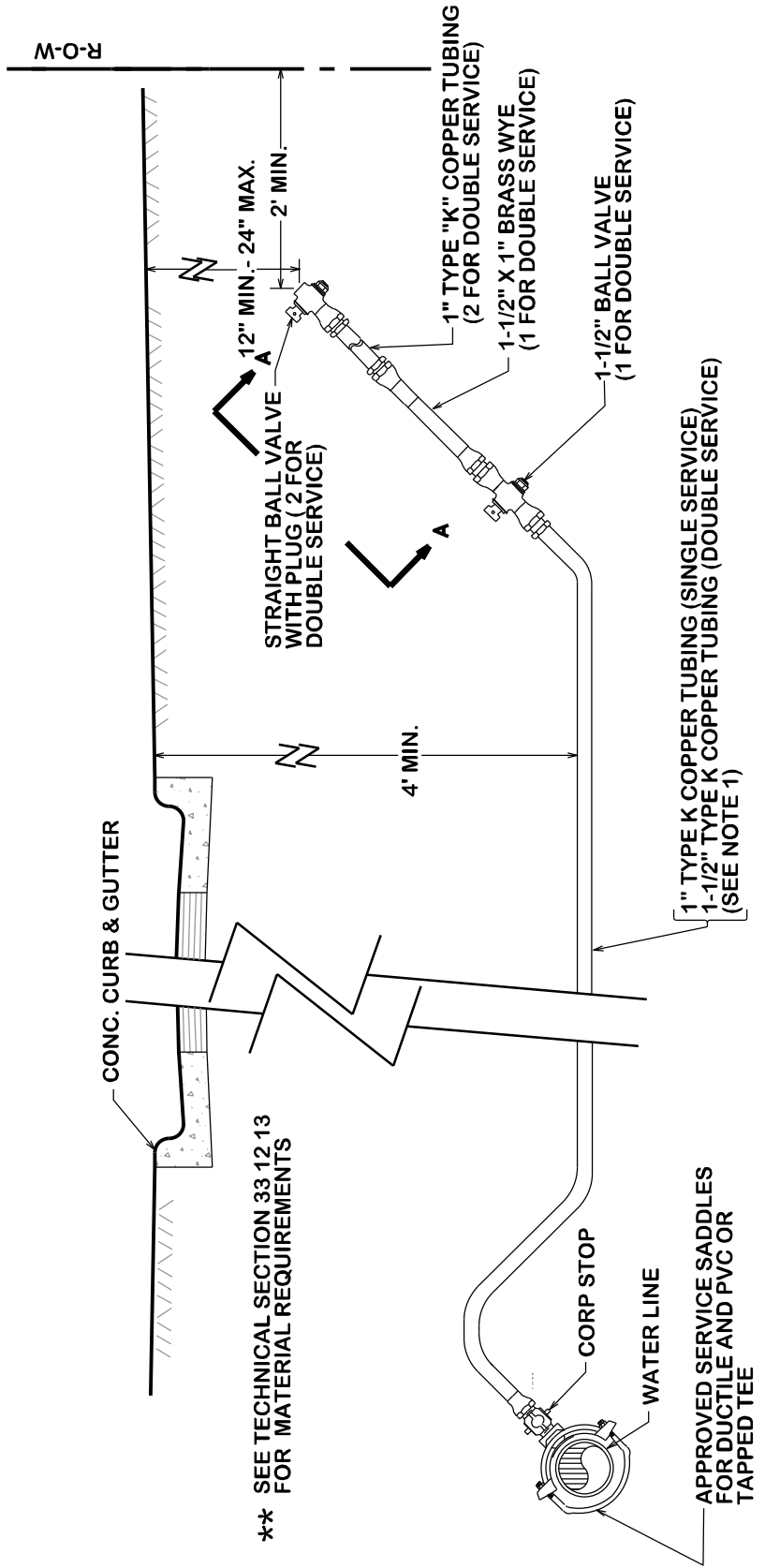

\*\* SEE TECHNICAL SECTION 33 12 13 FOR MATERIAL REQUIREMENTS



**NEW WATER SERVICE  
(SHORT AND LONG SIDE)**

DATE  
**JAN. 2009**

**B/CS UNIFIED  
STANDARD DETAIL**

DETAIL NO.  
**W2-01**

